

S9F174DND



Product Family	Freezers
Installation	Built-in
Built-In Niche	178
Category	Single door
Reference width	Until 60
Reference height	160 - 200
Cooling type	No Frost
Hinge type	Door on door
Hinge position	Right
Reversible door	Yes



Aesthetics



Aesthetic	Universal	Logotipo	Logotipo serigrafado
Colour	White	Cor do perfil das gavetas	Silver
Side material	Metal	Display	LCD Touch
Side colour	White		

Freezer compartment features

Internal light in freezer	No
Type of internal light (freezer)	No
Number of drawers	5
No. of compartments with flap	2

Other technical features



Freezer compartment accessories	Ice cube tray	No. of compressors	1
Functions display	Fast Freezing, Control lock, Temperature Alarm, Cooling timer	Refrigerant gas type	R600a
Fast freezing button	Yes	Type of compressor	Inverter
Door open alarm	Yes	Quantidade de refrigeracao (gr.)	55 g
Temperature alarm	Yes	Espuma expansiva de isolamento	Ciclopentano
Antibacterial Gasket	No	Peso máximo do painel para a porta do congelador	25 kg

Type of temperature control Electronic

Etiqueta de Desempenho / Energia - Reg. 2019







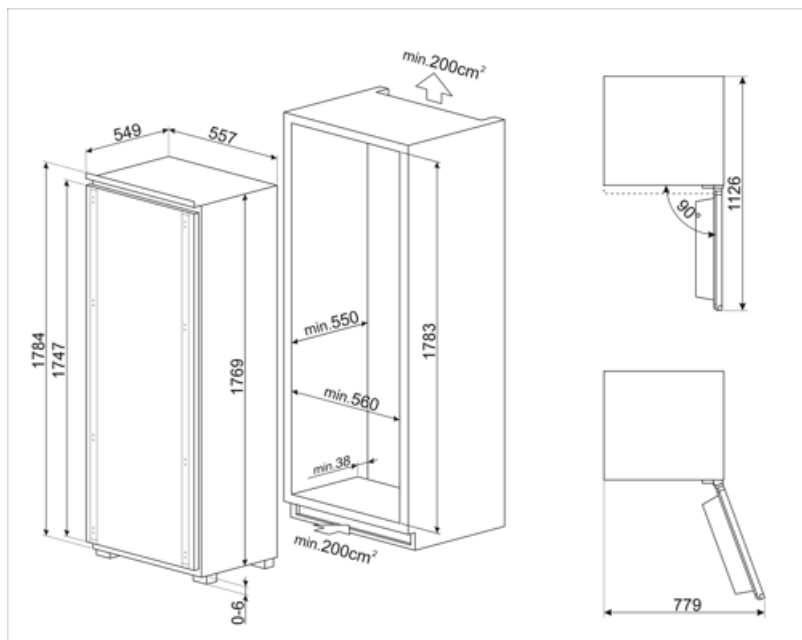

Consumo de energia anual	189 kWh/a	Autonomia de conservação sem energia elétrica	10 h
Volume líquido total	212 l	4 estrelas - Capacidade de congelamento	18.5 Kg/24h
Classe de eficiência energética	D	Classe climática	SN, N, ST, T
Classe de emissão de ruído acústico aerotransportado	B	EI	80 %
Soma dos volumes do(s) compartimento(s) congelado(s)	212 l		

Electrical Connection

Plug	(F;E) Schuko	Voltage	230-240 V
Electrical connection rating	140 W	Frequency (Hz)	50 Hz
Current	1 A	Comprimento do cabo de alimentação	240 cm



Symbols glossary

- | | | | |
|--|--|---|---|
|  | Bloqueio para crianças: alguns modelos estão equipados com um dispositivo para bloquear o programa/ciclo para que não possa ser acidentalmente alterado. |  | Display LCD: para otimizar o desempenho e simplificar o uso do aparelho. |
|  | CONGELAMENTO RÁPIDO: A função de congelamento rápido reduz a temperatura do compartimento quando ativado algumas horas antes do uso. |  | Tecnologia do inversor: A evolução dos secadores Smeg para modelos mais inteligentes e ambientalmente sustentáveis levou à escolha do uso da tecnologia do inversor com bombas de calor, o que reduz significativamente o consumo de energia. |
|  | Nicho incorporado |  | No Frost: Os sistemas sem geada e livre de geada impedem a formação de gelo, de modo que não é necessário descongelar. |
|  | Classe de eficiência energética D | | |