

SBS63XDF



Product Family	Refrigerator
Installation	Free Standing
Category	Side-by-side
Reference width	Higher than 80 cm
No-Frost system	Total
Cooling type	Fan assisted refrigerator, no-frost freezer
Defrost	Automatic
Hinge type	Standard
EAN code	8017709293246



Aesthetics



Aesthetics	Universal	Side material	Steel
Colour	Inox Look	Side colour	Silver
Design	Flat	Logo	Applied
Material	Steel Effect	Drawers profile colour	Silver
Handle	External	Colour of glass shelf profile	Silver
Handle type	Fixed	Display	LED
Handle colour	Stainless steel	Display position	External (on door)
Logo colour	Chrome		

Refrigerator compartment features



No. of adjustable shelves	3	Type of crisper/vegetable drawers cover	Glass
Number of fruit and vegetables drawers	2	Life Plus zone-0°C	Yes
Shelves material	Glass	Internal light in fridge	Yes
Type of crisper/vegetable drawers cover	Standard	Type of internal light (fridge)	LED
Crisper Cover	Yes		

Refrigerator Inner Door

No. of bottle shelves	1
-----------------------	---

Number of adjustable door shelves 4

Other Refrigerator features



Accessories	Egg tray	Fan	Yes
Natural Plus Blu Light	Yes	Ionizer	Yes
MultiFlow	Yes	Antibacterial odour filter	Yes

Freezer compartment features

Number of drawers	2	Type of internal light (freezer)	LED
No. of shelves	4	Type of shelves	Glass
Internal light in freezer	Yes		

Freezer Inner Door

No. of adjustable door shelves 4

Other Freezer features



Ice maker	Manual	Fast freezing compartment	Yes
-----------	--------	---------------------------	-----

Other technical features



Functions display	Holiday, Fast freezing, Fast cooling, ECO, Control lock, Temperature alarm
Fast freezing button	Yes
Door open alarm	Yes
Temperature Alarm	Yes
Type of temperature control	Electronic
No. of compressors	1
Refrigerant gas type	R600a
Refrigerant Quantity (g)	62 g
Foam agent	Cyclopentane

Performance / Energy Label

Annual energy consumption	405 kWh/year	Noise level	38 dB(A) re 1 pW
Energy efficiency class	F	Thaw time	9 h
Airborne acoustical noise emission class	C	4 star - Freezing capacity	13,0 kg/24h
Total volume	580 l	Climatic class	SN, N, ST, T
Sum of the volumes of the frozen compartment(s)	212 l	EI	123 %
Sum of the volumes of the chill compartment(s) and the unfrozen compartment(s)	368 l		

Electrical Connection







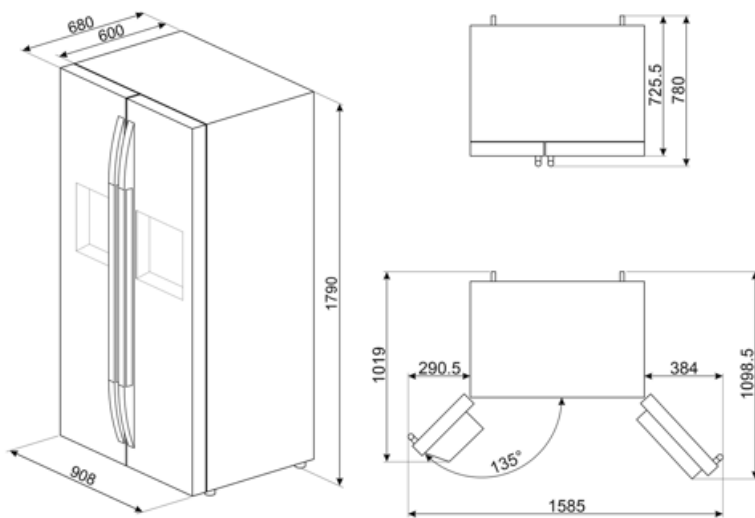









Nominal power	150 W	Frequency (Hz)	50 Hz
Current	0,85 A	Power supply cable length	215 cm
Voltage (V)	220-240 V	Plug	(F;E) Schuko

Logistic Information

Width (mm)	910 mm	Product Height with feet	1790 mm
Depth without handle	705 mm		



Symbols glossary

 <p>4 stars freezing compartment for better food preservation.</p>	 <p>A+: Energy efficiency class A+ helps to save up to 10% energy compared to class A. Maximum performance with minimum consumption is guaranteed.</p>
 <p>Smeg Active Ion system improves the quality of the air inside the cell. Thanks to the generation of negatively charged ions released inside the fridge Active Ion system neutralizes unpleasant dust.</p>	 <p>The automatic defrost system works by automatically defrosting at regular intervals eliminating the need to defrost altogether.</p>
 <p>Child lock: some models are fitted with a device to lock the programme/cycle so it cannot be accidentally changed.</p>	 <p>LED display: to show programmes, functions and options selected and the time to the end of the cycle.</p>
 <p>Economical mode: Analyzes fridge functioning during the activation and optimizes the operating cycle in order to reduce power consumption.</p>	 <p>Ventilated: Forced distribution of cold air in the refrigerator compartment, which allows even temperature distribution within the fridge.</p>
 <p>Fast freezing: The fast freezing function brings the temperature of the compartment down when activated a few hours prior to usage.</p>	 <p>Power saving mode: The power saving mode allows you to disable the refrigerator and keep the freezer working.</p>
 <p>LED interior lighting: is a more energy efficient and long lasting way of illuminating the interior of the appliance.</p>	 <p>Life Plus 0°C: The temperature in the Lifeplus compartments is kept at 0°C, which preserves fresh meat and fish longer.</p>
 <p>Air plus: keeps food fresher for longer.</p>	 <p>Natural Plus Blu Light: This unique Natural Plus Blu Light system works with nature to increase the storage time of fruit and vegetables.</p>
 <p>No Frost: The No Frost and Frost free systems prevent ice from forming so that no defrosting is required.</p>	 <p>Energy efficiency class F</p>