

# SCB60MX9

Cooker size	60x60 cm
N.º de cavidades com rótulo energético	1
Fonte de calor da cavidade	ELECTRICITY
Hob type	Gas
Tipo de forno principal	Thermo-ventilated
Sistema de limpeza no forno principal	Vapor Clean
EAN code	8017709166465
Energy efficiency class	A



## Aesthetics



<b>Aesthetic</b>	Mista	<b>Control knobs</b>	Smeg Classic
<b>Serie</b>	Concerto	<b>Controls colour</b>	Stainless steel
<b>Design</b>	Standard	<b>No. of controls</b>	6
<b>Colour</b>	Stainless steel	<b>Cor da serigrafia</b>	Serigrafia em preto
<b>Acabamento</b>	Satin	<b>Display</b>	electronic 5 buttons
<b>Command panel finish</b>	Stainless steel	<b>Door</b>	Full glass
<b>Logo</b>	Logotipo embutido	<b>Glass type</b>	Stopsol
<b>Posição do logotipo</b>	Logotipo no painel abaixo do forno	<b>Handle</b>	Smeg round handle
<b>Lid</b>	Grey glass with two strips	<b>Handle Colour</b>	Brushed stainless steel
<b>Cor da placa</b>	Stainless steel	<b>Storage compartment</b>	Door
<b>Type of pan stands</b>	Matt black enamelled flat	<b>Sliding compartment</b>	No
<b>Type of control setting</b>	Control knobs	<b>Feet</b>	Silver

## Programs / Functions

No. of cooking functions 6

Traditional cooking functions



Static



Fan assisted



Circulaire



Eco



Large grill



Fan assisted bottom

Recipes No

## Cleaning functions

 Vapor clean

## Hob technical features

 UR

**Total no. of cook zones** 4

Front left - Gas - UR - 3.50 kW

Rear left - Gas - Semi Rapid - 1.75 kW

Rear right - Gas - Semi Rapid - 1.75 kW

Front right - Gas - AUX - 1.00 kW

**Type of gas burners** Standard

**Gas safety valves** Yes

**Automatic electronic ignition** Yes

**Burner caps** Matt black enamelled

## Main Oven Technical Features



**No. of lights** 1

**Net volume of the cavity** 70 l

**Gross volume, 1st cavity** 79 l

**Cavity material** Ever Clean enamel

**No. of shelves** 5

**Type of shelves** Metal racks

**Roof Liner** No

**Light type** Halogen

**Light Power** 40 W

**Cooking time setting** Start and Stop

**Light when oven door is open** Yes

**Door opening** Flap down

**Removable door** Yes

**Full glass inner door** Yes

**Removable inner door** Yes

**Total no. of door glasses** 3

**No. of thermo-reflective door glasses** 1

**Safety Thermostat** Yes

**Heating suspended when door is opened** No

**Cooling system** Tangential

**Door Lock During Pyrolysis** No

**Usable cavity space dimensions (HxWxD)** 360X460X425 mm

**Temperature control** Electro-mechanical

**Lower heating element power** 1200 W

**Upper heating element - Power** 1000 W

**Grill element** 1700 W

**Large grill - Power** 2700 W

**Circular heating element - Power** 2000 W

**Grill type** Electric

**Tilting grill** No

**Soft Close system** No

## Options Main Oven

**Timer** Yes

**End of cooking acoustic alarm** Yes

**Minimum Temperature** 50 °C

**Maximum temperature** 260 °C

## Accessories included for Main Oven & Hob

Moka stand	1	40mm deep tray	1
Rack com batente traseiro e lateral	1		

## Electrical Connection

Plug	(F;E) Schuko	Electric cable	Installed, Single phase
Electrical connection rating	2800 W	Comprimento do cabo de alimentação	110 cm
Current	13 A	Frequency	50/60 Hz
Voltage	220-240 V	Bloco de terminais	3 polos

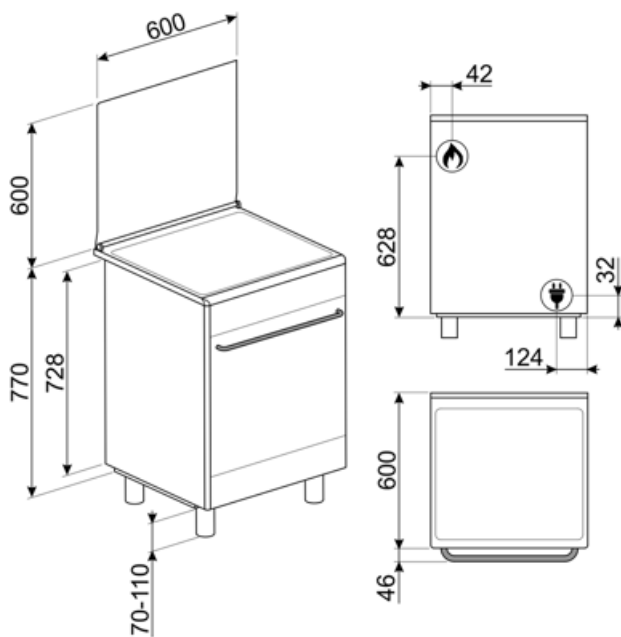

## Compatible Accessories

### AIRFRY

Air fryer rack AIRFRY . Ideal for recreating traditional frying in the oven, but with fewer calories and less fat. It allows you to cook quickly and simply dishes such as French fries, fried vegetables and fish, ensuring perfect browning and crispiness.



### BBQ

Double sided plate BBQ. Suitable for recreating succulent and crispy dishes in the oven with the typical taste of grilled cooking. The ribbed side is particularly suitable for meats and cheeses. The smooth side for fish, seafood and vegetables.



### BN620-1

Tabuleiro esmaltado, 20mm de profundidade



### BNP608T

Bandeja revestida de teflon, 8mm de profundidade, a ser colocada na grade



### GTT

\*\* Guias telescópicas totalmente extraíveis (1 nível)\*\* Extração: 433 mm Material: Aço inoxidável AISI 430 polido

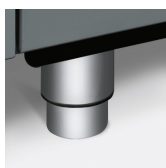

### KITPAX

Altura pés de extensão (950 mm), em aço inoxidável, adequado para fogões Master, Sinfonia e Concerto

### PALPZ

Pá para pizza com alça dobrável largura: 315mm comprimento : 325mm



### SMOLD

Conjunto de 7 moldes de silicone para sorvetes, gelados, pralinés, cubos de gelo ou para porção de alimentos. Utilizável de -60°C a +230°C

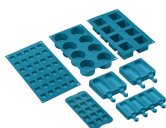

### AL60

Suporte adequado para fogões Concerto de 60 cm com placa a gás



### BG6090-1

Placa grelhadora de ferro fundido adequada para fogões Concerto



### BN640

Tabuleiro esmaltado, 40mm de profundidade

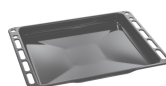

### GTP

\*\* Guias telescópicas parcialmente extraíveis (1 nível)\*\* Extração: 300 mm Material: Aço inoxidável AISI 430 polido



### KITP60X9

Painel anti-salpicos, 90 cm, aço inoxidável, adequado para fogões Concerto pirolíticos



### KITPD

Extensão de altura pés pretos (950 mm) para fogões



### SFLK1

Bloqueio para crianças





















### STONE

Pedra refratária retangular Ideal para cozinhar pizzas com os mesmos resultados de um forno típico a lenha. Também pode ser usado para assar pães, focaccias e outras receitas como tortas, flans ou biscoitos Dimensões:L42 x H1,8 x P37,5 cm.



## Symbols glossary

 <p>R: Desempenho de secagem do produto, medido de A++ a D/G, dependendo da família de produtos</p>	 <p>Instalação em coluna: Instalação em coluna</p>
 <p>Controle dos botões</p>	 <p>Sistema de arrefecimento a ar: para garantir temperaturas de superfície seguras.</p>
 <p>Portas envidraçadas triplas: Número de portas envidraçadas.</p>	 <p>Interior esmaltado: O interior em esmalte de todos os fornos Smeg tem um revestimento antiácido especial que ajuda a manter o interior limpo, reduzindo a quantidade de gordura de cozimento aderente a ele.</p>
 <p>Circogas: Em fornos a gás, o ventilador distribui o calor de forma rápida e uniforme por toda a cavidade do forno, evitando a transferência de sabor ao cozinhar vários pratos diferentes ao mesmo tempo. Em fornos elétricos, esta combinação completa o cozimento mais rapidamente de alimentos que estão prontos na superfície, mas que exigem mais cozimento no interior, sem mais escurecimento.</p>	 <p>Ventilador com elementos superiores e inferiores: Os elementos combinados com o ventilador visam fornecer calor mais uniforme, um método semelhante ao cozimento convencional, de modo que o pré-aquecimento é necessário. Mais adequado para itens que exigem métodos de cozimento lento.</p>
 <p>Somente elementos superior e inferior: um método de cozimento tradicional mais adequado para itens individuais localizados no centro do forno. A parte superior do forno será sempre mais quente. Ideal para assados, bolos de frutas, pão, etc.</p>	 <p>Circulaire: A combinação do ventilador e do elemento circular em torno dele dá um método de cozimento de ar quente. Isso oferece muitos benefícios, incluindo nenhum pré-aquecimento se o tempo de cozimento for superior a 20 minutos, nenhuma transferência de sabor ao cozinhar alimentos diferentes ao mesmo tempo, menos energia e tempos de cozimento mais curtos. Bom para todos os tipos de alimentos.</p>
 <p>ECO: A combinação da grelha, ventilador e elemento inferior é particularmente adequada para cozinhar pequenas quantidades de alimentos.</p>	 <p>Elemento de grelha O uso de grelha dá excelentes resultados ao cozinhar carne de porções médias e pequenas, especialmente quando combinada com uma rotisseria (sempre que possível). Também é ideal para cozinhar salsichas e bacon.</p>
 <p>Toda a porta interna de vidro: Toda a porta interna de vidro, uma única superfície plana que é simples de manter limpa.</p>	 <p>O vidro interior da porta: pode ser removido com alguns movimentos rápidos para limpeza.</p>
 <p>Luzes laterais: Duas luzes laterais opostas aumentam a visibilidade dentro do forno.</p>	 <p>Abertura automática: alguns modelos têm porta de abertura automática quando o ciclo é terminado, o que é uma solução perfeita para unidades de cozinha sem alça, pois nenhuma alça é necessária. Por razões de segurança, a porta trava automaticamente quando a máquina está em uso para evitar que seja aberta inadvertidamente.</p>
 <p>O compartimento do forno tem 5 níveis de cozimento diferentes.</p>	 <p>Queimadores ultrarrápidos: Queimadores ultrarrápidos potentes oferecem até 5kw de potência.</p>



Limpeza a Vapor: uma função de limpeza simples que utiliza vapor para afrouxar os depósitos no compartimento do forno.



A capacidade indica a quantidade de espaço útil no compartimento do forno em litros.

## Benefit (TT)

---

### **Gas hob**

Gas provides permanent control of the heat source and the temperature change is immediate

Equipped with a thermocouple, the gas supply is cut off if the flame is extinguished for greater safety.

### **Vapor Clean**

By inserting water into a recess at the bottom of the cavity, steam is generated, which softens the residue and facilitates its removal

By inserting water into a recess at the bottom of the cavity, steam is generated, which softens the residue and facilitates its removal.

### **Buttons control**

Easy and intuitive timer setting with a simple buttons

### **Storage compartment**

More space thanks to the lower compartment, ideal for storing accessories or cooking utensils

### **True-convection**

The best cooking performances guaranteed by ventilated circular flow

Multiple fans and heating elements guarantee the perfect aerodynamic heat flow, allowing homogeneous and quicker cooking inside the cavity.

### **Multilevel cooking**

Several cooking levels allow maximum flexibility of use

### **Multilevel halogen light**

Internal halogen lighting on different levels guarantees excellent visibility

### **Removable inner glass**

Internal door glasses are easily removable for complete cleaning

### **Tangential cooling**

New cooling system with tangential fan and airflow from the door to the splashback

### **Isothermic Cavity**

The best cooking performance at the highest energy efficiency

### **BBQ (optional accessory)**

Barbeque cooking directly in the oven with the double-sided grill (BBQ optional accessory)

**Pizza stone (optional accessory)**

Baking with refractory stone for soft and crispy pizza and yeast products (STONE optional accessory)

**Adjustable height**

Cooker top flushed with the working area thanks to adjustable feet

**Cold door**

During any function, the external door glass is cold, avoiding any risk of burns

**AirFry (AIRFRY optional accessory)**

Lighter and tastier food thanks to airfry basket (optional accessory)