

SCB91MFX9

Categorie fornuis	90x60 cm
Aantal ovens met energielabel	1
Cavity heat source	Elektrisch
Type kookplaat	Gas
Type primaire oven	Thermogeventileerd
Reinigingssysteem primaire oven	Vapor Clean
EAN-code	8017709215033
Energie-efficiëntieklasse	A



Design



Esthetiek	Classici	Bedieningsknoppen	Smeg Classici
Series	Concerto	Kleur knoppen	Roestvrij staal
Design	Standaard	Aantal bedieningsknoppen	7
Kleur	Roestvrij staal	Kleur serigrafie	Zwart
Afwerking	Geborsteld	Display	Elektronisch 5 toetsen
Afwerking bedieningspaneel	Roestvrij staal	Deur	Met 2 horizontale stroken
Logo	In reliëf	Type glas	Stopsol
Positie logo	Strook onder de oven	Handgreep	Smeg Classici
Upstand	Ja	Kleur handgreep	Geborsteld roestvrijstaal
Kleur kookplaat	Roestvrij staal	Opbergruimte	Klep
Type pannendragers	Gietijzer	Pootjes	Zilver
Type bediening	Bedieningsknoppen		

Programma's / functies

Aantal kookfuncties 8

Traditionele kookfuncties



Statisch



Geventileerd



Circulaire



ECO

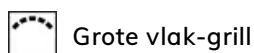

Grote vlak-grill

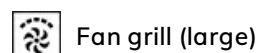

Fan grill (large)

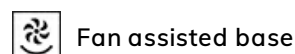

Fan assisted base



Draaispit

Schoonmaak functie

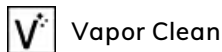

Technische specificaties kookplaat



Totaal aantal kookzones 5

Linksvoor - Gas - RP - 2.90 kW

Linksachter - Gas - SRD - 1.80 kW

Midden - Gas - URP - 4.00 kW

Rechtsachter - Gas - SRD - 1.80 kW

Rechtsvoor - Gas - AUX - 1.00 kW

Type gasbranders	Standaard	Thermobeveiliging	Ja
Automatische vonkontsteking	Ja	Branderdeksels	Mat zwart geëmailleerd

Technische specificaties primaire oven



Netto inhoud	115 l	Aantal ruiten ovendeur	3
Bruto inhoud 1e oven	129 l	Aantal thermo-reflecterende ruiten	1
Materiaal ovenruimte	Ever Clean emaille	Veiligheidsthermostaat	Ja
Aantal kookniveaus	5	Koelsysteem	Mantelkoeling
Type ovenrekken	Metalen zijsteunen	Afmetingen bruikbare interne ovenruimte (hxbxd)	371x724x418 mm
Soort verlichting	Halogeen	Temperatuurregeling	Elektro-mechanisch
Vermogen lamp	40 W	Onderwarmte - vermogen	1700 W
Instelling kooktijd	Start en stop	Bovenwarmte - vermogen	1200 W
Automatische inschakeling verlichting bij openen deur	Ja	Grill - vermogen	1700 W
Deur openen	naar beneden	Grote vlakgrill - vermogen	2900 W
Uitneembare ovendeur	Ja	Circulatie - vermogen	2 x 1550 W
Volledig glazen binnendeur	Ja	Type grill	Elektrisch
Uitneembaar glas binnendeur	Ja		

Opties primaire oven

Timer	Ja	Minimum temperatuur	50 °C
Akoestisch signaal einde kooktijd	Ja	Maximum temperatuur	260 °C

Meegeleverde accessoires primaire oven en kookplaat

Houder t.b.v. caffettiera	1	Bakplaat (20 mm)	1
---------------------------	---	------------------	---

Rek met achter- en zijstop	2	Bakplaat (40 mm)	1
----------------------------	---	------------------	---

Elektrische aansluiting

Aansluitwaarde	3200 W	Spanning 2 (V)	380-415 V
Stroom	14 A	Frequentie	50/60 Hz
Spanning	220-240 V	Aansluitkast	3 polig

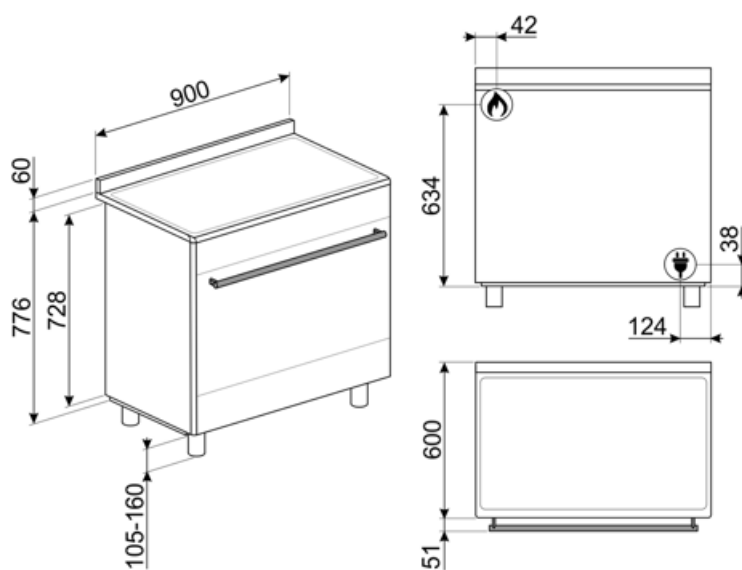

Compatibele Accessoires

AIRFRY9

Air fryer rack AIRFRY . Ideal for recreating traditional frying in the oven, but with fewer calories and less fat. It allows you to cook quickly and simply dishes such as French fries, fried vegetables and fish, ensuring perfect browning and crispiness.



BBQ9



BN920



GTP

Gedeeltelijk uittrekbare telescopische geleiders (1 niveau)



KIT600SNL-9

Cover strip for hob back side, depth 60mm, suitable for 90cm single oven Concerto cookers



KITH95

Hoogte uitbreidingsset (min.13cm - max.19,5cm), roestvrij staal



PALPZ

Pizzaschep met inklapbare handgreep breedte: 315 mm lengte: 325 mm



SFLK1

Kinderslot



AL90X9

Opstand geschikt voor 90cm Concertofornuizen met gaskookplaat en MF oven



BG6090-1

Gietijzeren grillplaat geschikt voor Concerto fornuizen



BN940



GTT

Volledig uittrekbare telescopische geleiders (1 niveau)



KIT90X9-1

Splashback, stainless steel, 90cm, for Concerto cookers with single MF or gas oven

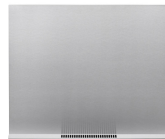

KITPDQ

Height reduction feet (850mm), stainless steel, for Concerto cookers (850-881mm)



PPR9

Refractory pizza stone without handles. Squared shaped stone: L64xH2,3xP37,5 cm Suitable also for gas ovens, to be put on the griddle.







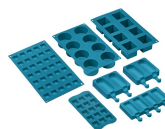

















SMOLD

Set van 7 siliconen vormpjes voor ijsjes, ijslolly's, pralines, ijsblokjes of om etenswaren te portioneren. Bruikbaar van -60 ° C tot + 230 ° C



Symbols glossary

 <p>A: Droogprestaties van het product, gemeten vanaf A +++ tot D / G afhankelijk van de productfamilie</p>	 <p>Heavy duty gietijzeren pannendragers: voor maximale stabiliteit en sterkte.</p>
 <p>Installation in column: Installation in column</p>	 <p>Luchtkoelsysteem: om een veilig oppervlak te garanderen temperaturen.</p>
 <p>Deuren met driedubbele beglazing: aantal glazen deuren.</p>	 <p>Geëmailleerde binnenkant: De geëmailleerde binnenkant van alle Smeg-ovens heeft een speciale antacidumvoering die helpt om de binnenkant schoon te houden door de hoeveelheid kookvet te verminderen.</p>
 <p>Fan assisted base: the mix of fan and lower heating element alone allows to finish cooking foods already cooked on the surface but not internally more quickly. This system is recommended to finish cooking foods that are already well cooked on the surface, but not internally, which therefore require a moderate higher heat. Ideal for any type of food.</p>	 <p>Ventilator met bovenste en onderste elementen: de elementen in combinatie met de ventilator zijn bedoeld om een meer gelijkmatige warmte te bieden, een methode die vergelijkbaar is met conventioneel koken, dus voorverwarmen is vereist. Het meest geschikt voor items die langzaam koken vereisen.</p>
 <p>De ovenruimte wordt tegelijk door het onder- en bovenelement verwarmt. De hitteverdeling over het gerecht is afhankelijk van het niveau waarop men dit plaatst. Geschikt voor bakken op 1 niveau. Gerechten: alle ovenschotels, vlees, gevogelte, brood, (gevulde) taarten. Speciaal: gans en eend (bevatten veel vet).</p>	 <p>Circulaire: it is the perfect function for cooking all types of dishes in a more delicate way. The heat comes from the back of the oven and is distributed quickly and evenly The fan is active. It is also ideal for cooking on multiple levels without mixing smells and flavors.</p>
 <p>ECO: low energy consumption cooking: this function is particularly suitable for cooking on a single shelf with low energy consumption. It is recommended for all types of food except those that can generate a lot of moisture (for example vegetables). To achieve maximum energy savings and reduce time, it is recommended to put the food in the oven without preheating the cooking compartment</p>	 <p>De warmte wordt geproduceerd door het grill- en bovenelement. Verhitting over het volledige oppervlak. De thermostaat wordt, afhankelijk van het gerecht, in de regel op de maximale stand gezet. Bij een korte baktijd kan de ovendeur gesloten blijven; bij langere baktijd blijft deze gedeeltelijk geopend. Voor vleesgerechten (klein- en middelgroot), vleespennen, vis, groenten, gratineren etc.</p>
 <p>Ventilator met grillelement: De ventilator vermindert de felle hitte van de grill en biedt een uitstekende methode om verschillende soorten voedsel, karbonades, steaks, worstjes enz. Te grillen, waardoor het gelijkmatig bruin wordt en de warmte wordt verdeeld, zonder het voedsel uit te drogen. De bovenste twee niveaus die voor gebruik worden aanbevolen, en het onderste deel van de oven kunnen worden gebruikt om gerechten tegelijkertijd warm te houden, een uitstekende mogelijkheid bij het bereiden van een gegrild ontbijt. Halve grill (alleen middengedeelte) is ideaal voor kleine hoeveelheden voedsel.</p>	 <p>Rotisserie: The rotisserie (where installed) works in combination with the grill element to brown foods to perfection.</p>

-
- | | |
|---|---|
|  All glass inner door: All glass inner door, a single flat surface which is simple to keep clean. |  The inner door glass: can be removed with a few quick movements for cleaning. |
|  verlichting |  Automatic opening: some models have Automatic opening door when the cycle is finished which is a perfect solution for handle-less kitchen units as no handle is needed. For safety reasons, the door locks automatically when the machine is in use to avoid it being opened inadvertently. |
|  The oven cavity has 5 different cooking levels. |  Ultrasnelle branders: Krachtige ultrasnelle branders bieden tot 5kw vermogen. |
|  Vapor Clean: a simple cleaning function using steam to loosen deposits in the oven cavity. |  The capacity indicates the amount of usable space in the oven cavity in litres. |
|  Knobs control | |

Benefit (TT)

Gas hob

Gas provides permanent control of the heat source and the temperature change is immediate

Equipped with a thermocouple, the gas supply is cut off if the flame is extinguished for greater safety.

Vapor Clean

By inserting water into a recess at the bottom of the cavity, steam is generated, which softens the residue and facilitates its removal

By inserting water into a recess at the bottom of the cavity, steam is generated, which softens the residue and facilitates its removal.

Buttons control

Easy and intuitive timer setting with a simple buttons

Storage compartment

More space thanks to the lower compartment, ideal for storing accessories or cooking utensils

True-convection

The best cooking performances guaranteed by ventilated circular flow

Multiple fans and heating elements guarantee the perfect aerodynamic heat flow, allowing homogeneous and quicker cooking inside the cavity.

Multilevel cooking

Several cooking levels allow maximum flexibility of use

Multilevel halogen light

Internal halogen lighting on different levels guarantees excellent visibility

Removable inner glass

Internal door glasses are easily removable for complete cleaning

Tangential cooling

New cooling system with tangential fan and airflow from the door to the splashback

Adjustable height

Cooker top flushed with the working area thanks to adjustable feet

Cold door

During any function, the external door glass is cold, avoiding any risk of burns

AirFry (AIRFRY optional accessory)

Lighter and tastier food thanks to airfry basket (optional accessory)

Isothermic Cavity

The best cooking performance at the highest energy efficiency

BBQ (optional accessory)

Barbeque cooking directly in the oven with the double-sided grill (BBQ optional accessory)

Pizza stone (optional accessory)

Baking with refractory stone for soft and crispy pizza and yeast products (STONE optional accessory)