

# SCV115AS



Familie  
 Installatie  
 Ontdooien  
 Type koelen  
 Type scharnier  
 Positie scharnier

Wijnklimaatkast  
 Vrijstaand  
 Automatisch  
 Geventileerd  
 Standaard  
 Links



## Eigenschappen compartimenten



Aantal vaste legplanken	1
Aantal uitneembare legplanken	5
Aantal uitneembare legplanken	1
Materiaal legplanken	Hout
Aanpasbare legplanken	Ja
Type interne verlichting	LED
Luchtfilter	Koolstoffilter

## Programma's/Functies



Bediening	Bedieningsknoppen	Kinderbeveiliging	Ja
Type bediening	Buitenkant onderaan	Temperature Alarm	Ja
Display	7 digits LED	Alarm open deur	Ja

## Technische specificaties

Aanpasbare temperatuurzones	2	Type koelgas	R600a
Temperatuur	5-22 °C	Hoeveelheid koelmiddel	80 g
Type temperatuurcontrole	Elektronisch	Schuimmiddel	Cyclopentaan
Anti-UV glazen deur	Ja	Metalen paneel op achterzijde koelkast	Plaatstaal
Geïntegreerd warmte-element	Ja	Aanpasbare voetjes	2 vooraan
		Opening deur	Met handvat

---

Aantal compressoren	1
Type compressor	Compressor lage vibraties

## Prestaties/Energie label - Reg. 2019

---

	<b>Annual energy consumption</b>	181 kWh/jaar	<b>Netto inhoud koelgedeeltes</b>	368 l
	<b>Energie-efficiëntieklasse</b>	G	<b>Klimaatklasse</b>	SN, N, ST
	<b>Emissieklasse voor akoestisch luchtgeluid</b>	D	<b>EEl</b>	179 %
	<b>Totaal netto volume</b>	368 l	<b>Geluidsniveau</b>	42 dB(A) re 1 pW





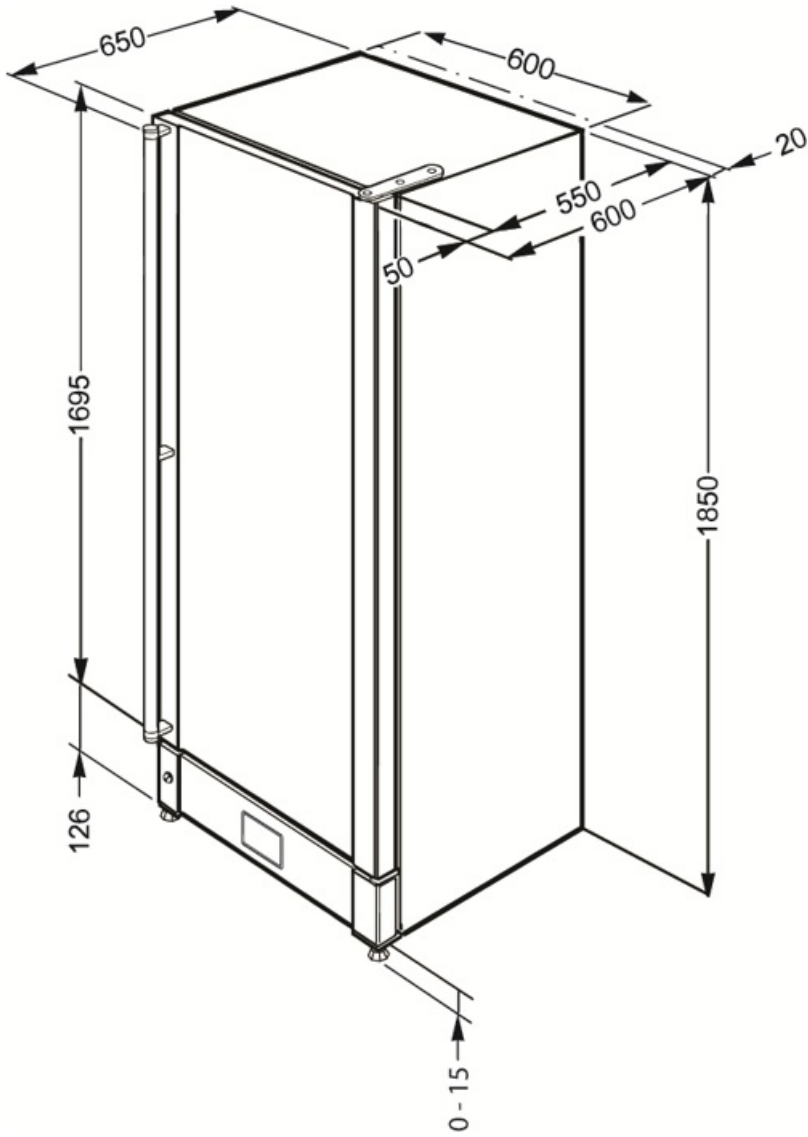

## Elektrische aansluiting

---

<b>Nominale aansluitwaarde</b>	200 W	<b>Frequentie (Hz)</b>	50 Hz
<b>Stroom (A)</b>	1 A	<b>Stekker</b>	(F;E) Schuko
<b>Spanning (V)</b>	220-240 V		



## Symbols glossary

- |  |   |   |  |
|--|---|---|--|
|  | The automatic defrost system works by automatically defrosting at regular intervals eliminating the need to defrost altogether. |  | Energy efficiency class A  |
|  | LED display: to show programmes, functions and options selected and the time to the end of the cycle.                           |  | Geventileerd: een geforceerde verdeling van koude lucht in het koelkast compartiment, die een gelijke temperatuurverdeling verzekert in de koelkast. |
|  | Fingerprint proof stainless steel: Fingerprint proof stainless steel keeps stainless steel looking as good as new.              |  | LED interior lighting: is a more energy efficient and long lasting way of illuminating the interior of the appliance.                                |
|  | Energie-efficiëntieklasse   |   |  |