

SE93SGH3



Product Family	Hob
Built-in type	Traditional
Dimensions	90 cm
Power supply	Gas
Type	Gas
EAN code	8017709105723



Aesthetics



Aesthetic	Classica
Colour	Stainless steel
Acabamento	Satin
Material	Stainless Steel
Type of steel	Brushed
Pan stands	Cast iron
Pan Stand Coating	No
Burner Coating	No
Type of control setting	Control knobs
Control knob position	Lateral
No. of controls	5
Controls colour	Silver
Illuminated control knobs	No
Alternative colours available	Stainless steel

Program / Functions

No. of gas cook zones	5
Total no. of cook zones	5

Options

Corte padrão	478x839-844 mm
--------------	----------------

Technical Features

UR

Front-left - Gas - UR - 4.10 kW

Rear-left - Gas - Semi Rapid - 1.80 kW

Central - Gas - FISH burner - 2.90 kW

Rear-right - Gas - Rapid - 2.60 kW

Front-right - Gas - AUX - 1.10 kW

Gas safety valves Yes Automatic Ignition Yes

Electrical Connection

Plug	No	Voltage 2 (V)	
Electrical connection rating (W)	1 W	Frequency (Hz)	50/60 Hz
Voltage (V)	220-240 V	Ficha eléctrica	No

Gas Connection

Gas Type	G20 Natural gas	Other gas connections provided	Conical
Ligação ao gás	Ligação ao gás cilíndrica	Gas connection rating (W)	12400 W
Other gas nozzles included	G30 GPL Liquid gas		

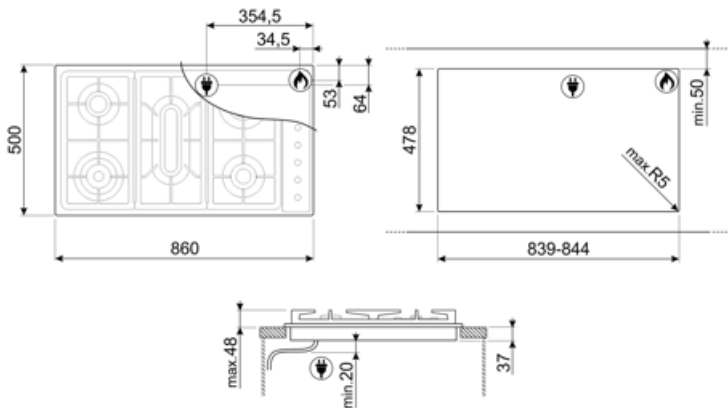

Symbols glossary



Instalação padrão: Instalação tradicional em tampo de mesa, adequado para qualquer conjunto de cozinha



Suportes de ferro fundido para serviço pesado: para máxima estabilidade e resistência.



Controle dos botões



Queimadores ultrarrápidos: Queimadores ultrarrápidos potentes oferecem até 5kw de potência.