

SF4104WMCN



Categorie	45 cm
Familie	Oven
Voeding	Elektrisch
Warmte bron	Elektrisch
Bereidingswijze	Combi-magnetron
Reinigingssysteem	Vapor Clean
EAN-code	8017709275914



Design

Esthetiek	Linea	Type zeefdruk	Symbolen
Kleur	Zwart	Deur	Geheel glas
Design	Plat	Handgreep	Linea
Materiaal	Glas	Kleur handgreep	Zwart
Type glas	Clear1	Logo	Geëtst
Kleur serigrafie	Grijs		

Bediening



Naam display	VivoScreen	Aantal weergaven talen	11
Display technologie	TFT	Weergave taal	Italiano, English (UK), Français (FR), Nederlands, Español (ES), Português (PT), Svenska, Русский, Deutsch (DE), Dansk, Polski
Regeling bediening	Touch control		

Programma's / functies

Aantal kookfuncties	15
Automatische programma's	56
Personaliseerbare recepten	64

Traditionele kookfuncties

Statisch	Geventileerd	Circulaire
Turbohitte	ECO	Grote vlak-grill
Fan grill (large)	Base	Circulaire + bottom
Pizza		

Bereidingsfuncties met microgolven

Magnetron	Geventileerd	Circulaire
Microwave + grill	Opwarmen en regenereren	

Overige functies

Ontdooien op tijd	Ontdooien op gewicht	Rijsfunctie
Warmhoudfunctie	Bordenwarmfunctie	Sabbath

Schoonmaak functie

Vapor Clean

Opties



Opties	Automatische in- en uitschakeling	Showroom demo optie	Ja
tijdprogrammering		Begeleide demo functie	Ja
Timer	Ja	Snelgids	Ja
Timer	D	Geheugen	Ja, de 10 laatst gebruikte functies
Kinderbeveiliging	Ja	Snelle voorverwarming	Ja
Overige opties	Warmhoudfunctie, ECO-Light, Quick Start, Taalinstelling, Weergave digitale klok, ECO-Logic, Helderheid, Tonen, Tones volume	Instant GO	Ja
Smart cooking	Ja		

Technische specificaties



Minimum temperatuur	30 °C	Deur openen	Standaard opening
Maximum temperatuur	250 °C	Deur	Temperatuur gecontroleerde deur
Aantal kookniveaus	3	Totaal aantal ruiten	3
Aantal lampen	2		

Soort verlichting	Halogeen	Automatische uitschakeling magnetron bij openen deur	Ja
Vermogen lamp	40 W	Soft Close systeem	Ja
Automatische inschakeling verlichting bij openen deur	Ja	Koelsysteem	Mantelkoeling
Onderwarmte - vermogen	1000 W	Koelleiding	Enkel
Grill - vermogen	2000 W	Afmetingen bruikbare interne ovenruimte (hxbxd)	212x462x407 mm
Circulatie - vermogen	1400 W	Temperatuurregeling	Elektronisch
Automatische uitschakeling verhittingselementen bij openen deur	Ja	Materiaal ovenruimte	Ever Clean emaille
		Veiligheidsscherm magnetrondeur	Ja

Prestaties / energielabel



Netto inhoud	40 l	Effectief magnetronvermogen	1000 W
Aantal ovens	1		

Meegeleverde accessoires



Ovenrooster met stop	1	Glazen ovenplaat	1
Inzetrooster	1	Telescopische geleiders, gedeeltelijk uitschuifbaar	1

Elektrische aansluiting

Spanning	220-240 V	Frequentie	50 Hz
Stroom	14 A	Lengte voedingskabel	115 cm
Nominale aansluitwaarde	3100 W		

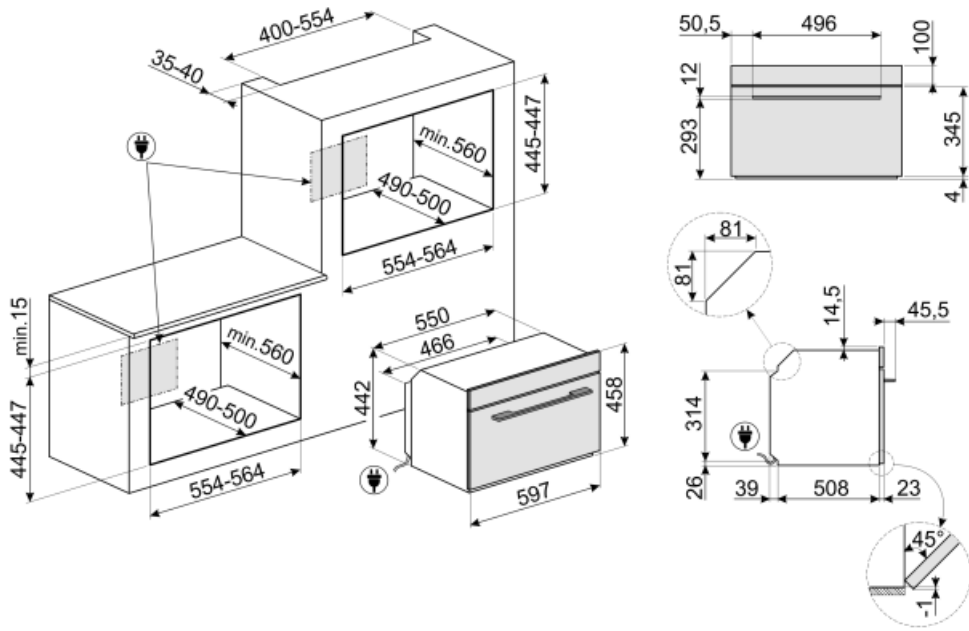

Accessoires niet inbegrepen

GTP

Gedeeltelijk uittrekbare telescopische geleiders (1 niveau)



BN620-1

Geëmailleerde bakplaat, 20 mm diep



GTT

Volledig uittrekbare telescopische geleiders (1 niveau)



PR3845X

Antifingerprint roestvrij staal.
Afdekstrip voor meubels in kolominstallatie van meer ovens



PALPZ

Pizzaschep met inklapbare handgreep
breedte: 315 mm lengte: 325 mm







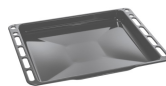



























BN640

Geëmailleerde bakplaat, 40 mm diep



Symbols glossary (TT)

 <p>Kinderslot: sommige modellen zijn voorzien van een apparaat om het programma / de cyclus te vergrendelen zodat het niet kan per ongeluk veranderd</p>	 <p>Combination microwave: This oven allows to combine two different ways of cooking (Traditional with microwaves). Combined ovens increase cooking opportunities, while providing maximum flexibility of household appliances.</p>
 <p>Luchtkoelsysteem: om een veilig oppervlak te garanderen temperaturen.</p>	 <p>Ontdooien op tijd: met deze functie wordt automatisch het tijdstip van ontdooien van voedsel bepaald</p>
 <p>Ontdooien op gewicht: Met deze functie wordt de ontdooitijd bepaald</p>	 <p>Deuren met driedubbele beglazing: aantal glazen deuren.</p>
 <p>Automatische verlichting gaat uit: voor meer energiebesparing schakelt de verlichting automatisch uit na één minuut na het begin van de bereiding.</p>	 <p>ECO-logic: optie stelt u in staat om de vermogenslimiet van de werkelijke energiebesparing van het apparaat te beperken</p>
 <p>Electric</p>	 <p>Geëmailleerde binnenkant: De geëmailleerde binnenkant van alle Smeg-ovens heeft een speciale antacidumvoering die helpt om de binnenkant schoon te houden door de hoeveelheid kookvet te verminderen.</p>
 <p>Ventilator met bovenste en onderste elementen: de elementen in combinatie met de ventilator zijn bedoeld om een meer gelijkmatige warmte te bieden, een methode die vergelijkbaar is met conventioneel koken, dus voorverwarmen is vereist. Het meest geschikt voor items die langzaam koken vereisen.</p>	 <p>De ovenruimte wordt tegelijk door het onder- en bovinelement verwarmt. De hitteverdeling over het gerecht is afhankelijk van het niveau waarop men dit plaatst. Geschikt voor bakken op 1 niveau. Gerechten: alle ovenschotels, vlees, gevogelte, brood, (gevulde) taarten. Speciaal: gans en eend (bevatten veel vet).</p>
 <p>De ovenruimte wordt uitsluitend verhit door het onderelement. Voor gerechten die een hoge basistemperatuur behoeven, heeft deze bakstand weinig tot geen invloed op de korst aan de bovenzijde. Geschikt voor bakken op 1 niveau, ideaal voor deeggerechten die moeten rijzen (bijv. pizza). Bij gevulde taarten zal de deegbodem beter droog blijven.</p>	 <p>Circulaire with lower element: The addition of the lower element adds extra heat at the base for food which requires extra cooking.</p>
 <p>Circulaire: it is the perfect function for cooking all types of dishes in a more delicate way. The heat comes from the back of the oven and is distributed quickly and evenly The fan is active. It is also ideal for cooking on multiple levels without mixing smells and flavors.</p>	 <p>ECO: low energy consumption cooking: this function is particularly suitable for cooking on a single shelf with low energy consumption. It is recommended for all types of food except those that can generate a lot of moisture (for example vegetables). To achieve maximum energy savings and reduce time, it is recommended to put the food in the oven without preheating the cooking compartment</p>

-  De warmte wordt geproduceerd door het grill- en bovinelement. Verhitting over het volledige oppervlak. De thermostaat wordt, afhankelijk van het gerecht, in de regel op de maximale stand gezet. Bij een korte baktijd kan de oven gesloten blijven; bij langere baktijd blijft deze gedeeltelijk geopend. Voor vleesgerechten (klein- en middelgroot), vleespennen, vis, groenten, gratineren etc.
-  Microwave: Penetrating straight into the food, microwaves cook very quickly and with considerable energy savings. Suitable for cooking without fat, they are also able to thaw and heat food without altering its original appearance and aroma. The microwave function can also be combined with conventional functions with all the resulting advantages. Ideal for all types of food.
-  Microwave + grill element: The use of the grill results in a perfect browning of the surface of the food. The action of microwaves allows instead of cooking in a short time the internal part of the food.
-  This function can reheat precooked dishes, without becoming dry or hard.
-  Turbo: the heat comes from 3 directions: above, below and from the back of the oven The fan is active. It allows quick cooking, even on several shelves without mixing the aromas. Ideal for large volumes or foods that require intense cooking.
-  KEEP_WARM_72dpi
-  Plate rack warming: function for heating or keeping dishes warm. Place the baking tray on the lowest shelf and stack the dishes to be heated.
-  Rapid preheating: cooking is preceded by the preheating phase which allows the cooking compartment to reach the set temperature. This option reduces the time by up to 50%.
-  Option designed to solve any doubts More than 100 pop-ups, which can be triggered with a long touch on any icon, provide information on the use of the display and cooking.
-  Ventilator met grillelement: De ventilator vermindert de felle hitte van de grill en biedt een uitstekende methode om verschillende soorten voedsel, karbonades, steaks, worstjes enz. Te grillen, waardoor het gelijkmatig bruin wordt en de warmte wordt verdeeld, zonder het voedsel uit te drogen. De bovenste twee niveaus die voor gebruik worden aanbevolen, en het onderste deel van de oven kunnen worden gebruikt om gerechten tegelijkertijd warm te houden, een uitstekende mogelijkheid bij het bereiden van een gegrild ontbijt. Halve grill (alleen middengedeelte) is ideaal voor kleine hoeveelheden voedsel.
-  Cooking with the simultaneous use of the heating element in combination with fan and microwave supply.
-  Fan combined with traditional cooking, where heat is generated from above and below, provides uniform heat. Adding the microwave function allows the same cooking results in less time.
-  Pizza function: Specific function for cooking pizza in a pan. It allows to obtain a pizza that is soft inside and crispy outside with the topping perfectly cooked, not dry and not burnt.
-  Compact appliances with a height of 45 cm - perfect solution to meet the functional requirements of kitchen sets of small height. Available in several types and in different styles.
-  verlichting
-  Air at 40°C provides the perfect environment for proving yeast type dough mixes. Simply select the function and place dough in the cavity for allotted
-  SABBATH: function that allows to cook food respecting Judaism's day of rest provisions.
-  The oven cavity has 3 different cooking levels.



Smart Cooking is the perfect recipe for every occasion. Meat, fish, pasta, desserts, etc . up to 150 automatic recipes that allow to make any preparation in a single click. Decide your menu and then the oven takes care of the rest.



Telescopic rails: allow you to pull out the dish and check it without having to remove it from the oven entirely.



Tilting grill: the tilting grill can be easily unhooked to move the heating element and clean the roof of the appliance in one simple step.



Vapor Clean: a simple cleaning function using steam to loosen deposits in the oven cavity.



The 4.3" VIVOscreen display offers an advanced colour touch interface, for automatic management of firing programmes such as Delta T, Multi-step and SameTime firing.



INSTANT GO: activating this option allow to start cooking immediately. Preheating is included in the cooking time and the oven will gradually reach the desired temperature Particularly suitable for frozen foods.



Soft close: all models are equipped with advanced function of smooth closing of the door, which allows the device to close smoothly and quietly.



Electronic control: Allows you to maintain temperature inside the oven with the precision 2-3 ° C. This enables to cook meals that are very sensitive to temperature changes, such as cakes, souffles, puddings.



Touch control: dankzij de gebruiksvriendelijke Touch control kan het apparaat met één druk op de knop worden geprogrammeerd.



The capacity indicates the amount of usable space in the oven cavity in litres.



Keep warm: the function allows to keep cooked food warm.