

SF4390VCX1



Category	45cm Compact Ovens
Product Family	Oven
Power supply	Electric
Heat source	Electric
Cooking method	Combi Steam
Cleaning system	Vapor Clean
EAN code	8017709235888



Aesthetics

Aesthetics	Classic	Serigraphy type	Symbols
Colour	Stainless steel	Door	With 2 horizontal strips
Finishing	Fingerproof	Handle	Classic
Design	Flat	Handle Colour	Stainless steel
Material	Stainless steel	Logo	Embossed
Type of steel	Brushed	Control knobs	Classic
Glass Type	Eclipse	Controls colour	Steel effect
Serigraphy colour	Black		

Controls

Display technology	LCD	No. of controls	2
Control setting	Control knobs		

Programs / Functions

No. of cooking functions	14
Automatic programmes	20

Traditional cooking functions

- | | | |
|--|--------------|-------------------|
| Static | Fan assisted | Ciculaire |
| Turbo (ciculaire + bottom + upper + fan) | ECO | Large grill |
| Fan grill (large) | Base | Fan assisted base |

Cooking functions with steam

- | | | |
|---------------------------|------------------------------|-------------------------|
| Manual steam | Steam + bottom + upper + fan | Steam + ciculaire + fan |
| Warming and re-generation | | |

Other Steam functions

- | | | |
|---------------------|--------------|-------------|
| Tank cleaning | Water outlet | Water input |
| Descaling programme | | |

Other functions

- | | | |
|-----------------|-------------------|---------|
| Defrost by time | Defrost by weight | Proving |
| Sabbath | | |

Cleaning functions

- | |
|-------------|
| Vapor Clean |
|-------------|

Options



- | | | | |
|-------------------------------------|---------------------------------------|-----------------------------|----------------------|
| Time-setting options | Delay start and automatic end cooking | Other options | Keep warm, Eco light |
| Minute minder | Yes | Showroom demo option | Yes |
| Controls Lock / Child Safety | Yes | Rapid pre-heating | Yes |

Technical Features



Capacity (Lt)	41 l
Minimum Temperature	30 °C
Maximum temperature	250 °C
Shelf positions	3
No. of lights	1
Light type	Halogen
Light power	40 W
Light when door is opened	Yes
Lower heating element power	1000 W
Grill element - power	2000 W
Circular heating element - Power	1400 W
Heating suspended when door is opened	Yes
Boiler - Power	900 W
Door opening type	Standard opening

Door	Temperate door
Removable door	Yes
Full glass inner door	Yes
Removable inner door	Yes
Total no. of door glasses	3
Soft Close hinges	Yes
Cooling system	Tangential
Cooling duct	Single
Usable cavity space dimensions (HxWxD)	212x462x407 mm
Temperature control	Electronic
Cavity material	Easy clean enamel
Water loading	Fill&Hide, automatic
Tank capacity	1,2 l
Steam stops when door is opened	Yes

Performance / Energy Label



Energy efficiency class	A+	Energy consumption in forced air convection	2,12 MJ
Net volume of the cavity	41 litres	Energy consumption per cycle in fan-forced convection	0,59 kWh
Energy consumption per cycle in conventional mode	0,85 kWh	Number of cavities	1
Energy consumption in conventional mode	3,06 MJ	Energy efficiency index	81,9 %

Accessories Included

Chrome shelf	1	St/steel tray (20mm)	1
Extra deep enamelled tray (40mm)	1	St/steel perforated deep tray (40mm)	1
Grill mesh	1	Other	Sponge/ Boiler cover/ Beaker

Electrical Connection

Voltage	220-240 V	Nominal power (W)	3100 W
Plug	No	Frequency (Hz)	50/60 Hz
Current	14 A	Power supply cable length	115 cm

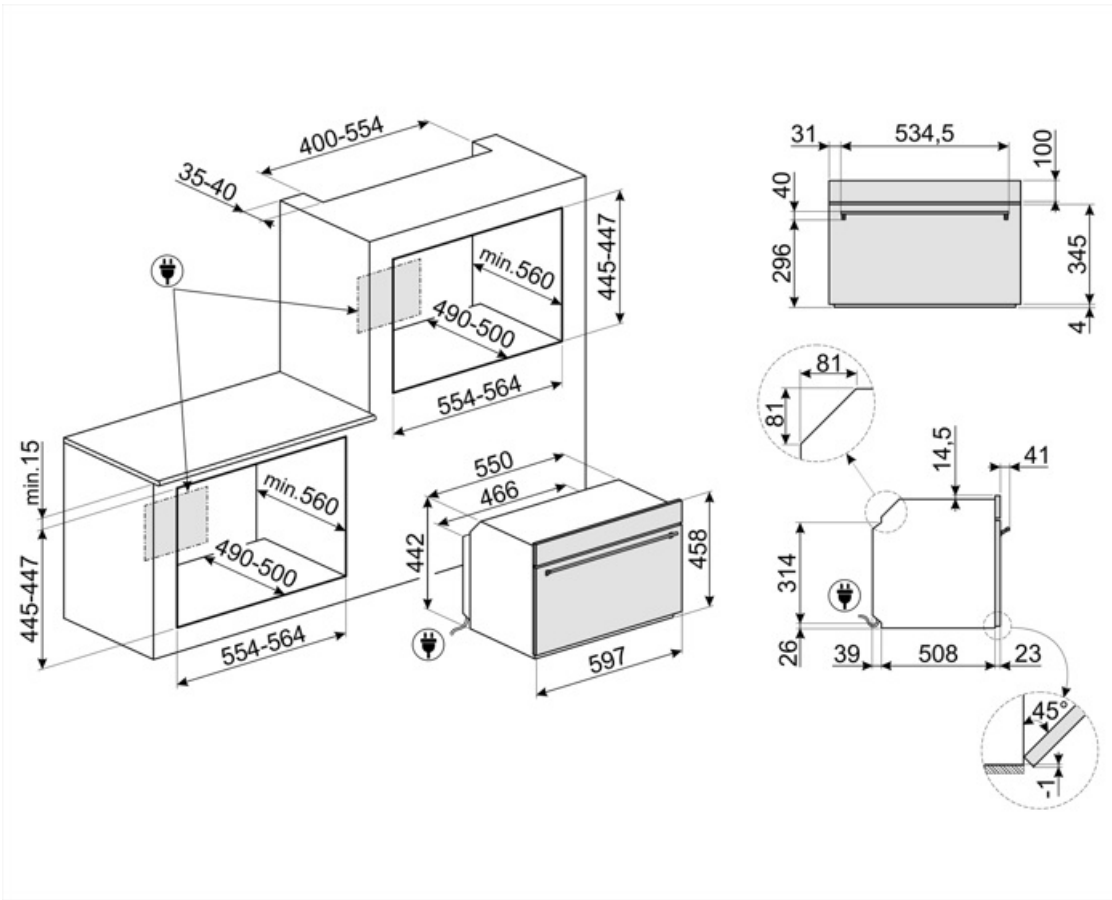

Compatible Accessories

BN620-1

Enamelled tray, 20mm deep



BX640

Stainless steel tray for steam oven,
H40xW455xD176 mm



PALPZ

Pizza shovel with fold away handle
width: 315mm length : 325mm



STONE2

Rectangular pizza stone without handles, suitable for 45cm and 60cm wide ovens. Dimensions W42 x H1.8 x D37.5cm. Ideal for cooking pizzas with the same results as a typical wood-fired oven. Can also be used for baking bread, focaccias and other recipes such as pies, flans or biscuits



BN640

Enamelled tray, 40mm deep



KIT330X

Trim kit for 45 cm Classica ovens











































PR3845X

Antifingerprint stainless steel. Cover for furniture in column installation of more ovens



Symbols glossary

 <p>A+: Energy efficiency class A+ helps to save up to 10% energy compared to class A. Maximum performance with minimum consumption is guaranteed.</p>	 <p>Child lock: some models are fitted with a device to lock the programme/cycle so it cannot be accidentally changed.</p>
 <p>Combination steam: ovens can be used either as a steam oven, or as a traditional oven, or alternatively the two methods can be combined.</p>	 <p>Air cooling system: to ensure a safe surface temperatures.</p>
 <p>Defrost by time: with this function the time of thawing of foods are determined automatically.</p>	 <p>Defrost by weight: With this function the defrosting time is determined</p>
 <p>Descaling function: Is essential to remove excess deposits of limestone in the tank and allow the proper operation of the product. The need to perform this operation is signaled by the product itself.</p>	 <p>Triple glazed doors: Number of glazed doors.</p>
 <p>Automatic lighting switches off: for greater energy savings, the lighting switches off automatically after one minute from the start of cooking.</p>	 <p>Electric</p>
 <p>Enamel interior: The enamel interior of all Smeg ovens have a special antacid lining which helps keep the interior clean by reducing the amount of cooking grease adhering to it.</p>	 <p>Fingerprint proof stainless steel: Fingerprint proof stainless steel keeps stainless steel looking as good as new.</p>
 <p>A FULL STEAM oven has 3 steam COMBINATION cooking functions available, and it is also possible to use it to cook with PURE steam only. The steam is adjustable between 30% and 70% and there is the option of 100% pure steam if required. The water is loaded into the oven before cooking via an automatic loading tube. The oven calculates the exact amount of water required for the desired cooking function, up to 1.2lt. Water is introduced into the cavity, and becomes steam during cooking. Continuous steam is generated based on the setting at the start of cooking.</p>	 <p>Fan assisted base: the mix of fan and lower heating element alone allows to finish cooking foods already cooked on the surface but not internally more quickly. This system is recommended to finish cooking foods that are already well cooked on the surface, but not internally, which therefore require a moderate higher heat. Ideal for any type of food.</p>
 <p>Fan with upper and lower elements: The elements combined with the fan aim to provide more uniform heat, a similar method to conventional cooking, so pre-heat is required. Most suitable for items requiring slow cooking methods.</p>	 <p>Upper and lower element only: a traditional cooking method best suited for single items located in the centre of the oven. the top pf the oven will always be hottest. Ideal for roast, fruit cakes, bread etc.</p>
 <p>Lower heating element only: This function is ideal for foods that require extra base temperature without browning, e.g. pastry dishes, pizza. Also suitable for slow cooking of stews and casseroles.</p>	 <p>Circulaire: The combination of the fan and circular element around it gives a hot air cooking method. This provides many benefits including no preheat if cook time is more than 20 minutes, no flavour transfer when cooking different foods at the same time, less energy, and shorter cook times. Good for all types of food.</p>

- | | |
|--|--|
|  <p>ECO: The combination of the grill, fan and lower element is particularly suitable for cooking small quantities of food.</p> |  <p>Grill element: Using of grill gives excellent results when cooking meat of medium and small portions, especially when combined with a rotisserie (where possible). Also ideal for cooking sausages and bacon.</p> |
|  <p>Fan with grill element: The fan reduces the fierce heat from the grill, providing an excellent method of grilling various foods, chops, steaks, sausages etc. giving even browning and heat distribution, without drying out the food. The top two levels recommended for use, and the lower part of the oven can be used to keep items warm at the same time, an excellent facility when cooking a grilled breakfast. Half grill (centre portion only) is ideal for small quantities of food.</p> |  <p>Steam cooking: it's a natural way of cooking for any kind of products, from vegetables to desserts, to preserve the nutritional and organoleptic properties of ingredients. Ideal for cooking without fat, to heat up food without drying. Steam is ideal for simultaneous cooking of meals that require different cooking times.</p> |
|  <p>Fan combined with traditional cooking, where heat is generated from above and below, provides uniform heat. Adding the steam function allows the same cooking results in less time.</p> |  <p>Circulaire element with steam: Cooking with the simultaneous use of the circular heating element in combination with fan and steam supply.</p> |
|  <p>FUN_STEAM_OTHER_WATER_IN_OUT_72dpi</p> |  <p>Reheat: This function can reheat precooked dishes, without becoming dry or hard.</p> |
|  <p>Circulaire with upper and lower elements: The use of the fan with both elements allows food to be cooked quickly and effectively, ideal for large joints that require thorough cooking. It offers a similar result to rotisserie, moving the heat around the food, instead of moving the food itself, enabling any size or shape to be cooked.</p> |  <p>Compact appliances with a height of 45 cm - perfect solution to meet the functional requirements of kitchen sets of small height. Available in several types and in different styles.</p> |
|  <p>All glass inner door: All glass inner door, a single flat surface which is simple to keep clean.</p> |  <p>The inner door glass: can be removed with a few quick movements for cleaning.</p> |
|  <p>Keep warm: This function allows you to keep precooked foods warm.</p> |  <p>Side lights: Two opposing side lights increase visibility inside the oven.</p> |
|  <p>ECO-logic: option allows you to restrict the power limit of the appliance real energy saving.</p> |  <p>Air at 40°C provides the perfect environment for proving yeast type dough mixes. Simply select the function and place dough in the cavity for allotted</p> |
|  <p>Rapid preheat: The rapid preheat function can be used to reach the selected temperature in just a few minutes.</p> |  <p>Sabbath: This function allows you to cook food whilst respecting the provisions of the Jewish day of rest.</p> |
|  <p>The oven cavity has 3 different cooking levels.</p> |  <p>Soft close: all models are equipped with advanced function of smooth closing of the door, which allows the device to close smoothly and quietly.</p> |
|  <p>To guarantee the optimal functioning of the appliance, it is suggested to carry out the tank cleaning roughly once every 2-3 months.</p> |  <p>Electronic control: Allows you to maintain temperature inside the oven with the precision 2-3 ° C. This enables to cook meals that are very sensitive to temperature changes, such as cakes, souffles, puddings.</p> |



Vapor Clean: a simple cleaning function using steam to loosen deposits in the oven cavity.



The capacity indicates the amount of usable space in the oven cavity in litres.



The capacity indicates the amount of usable space in the oven cavity in litres.