

SF6341GVXD



Category	60cm Single Ovens
Product Family	Oven
Power supply	Gas
Heat source	Gas
Cooking method	Fan assisted
EAN code	8017709211196



Aesthetics

Aesthetics	Classic	Serigraphy type	Symbols
Colour	Stainless steel	Door	With 2 horizontal strips
Finishing	Fingerproof	Handle	Classic
Design	Flat	Handle Colour	Stainless steel
Material	Stainless steel	Logo	Embossed
Type of steel	Brushed	Control knobs	Classic
Glass Type	Eclipse	Controls colour	Steel effect
Serigraphy colour	Black		

Controls

Control setting	Control knobs	No. of controls	3
-----------------	---------------	-----------------	---

Programs / Functions

No. of cooking functions 8

Traditional cooking functions

Large grill	Fan grill (large)	Base
Fan assisted base	Rotisserie	Fan rotisserie
Rotisserie + grill	Rotisserie + fan grill	

Options

Time-setting options	No delay options	Minute minder	Yes
----------------------	------------------	---------------	-----

Technical Features



Capacity (Lt)	63 l	Removable door	Yes
Minimum Temperature	150 °C	Full glass inner door	Yes
Maximum temperature	265 °C	Removable inner door	Yes
Shelf positions	4	Total no. of door glasses	3
No. of lights	1	Cooling system	Tangential
Light type	Halogen	Cooling duct	Single
Light power	40 W	Gas safety valve	Yes
Light when door is opened	Yes	Usable cavity space dimensions (HxWxD)	316x444x425 mm
Grill element - power	1800 W	Cavity material	Easy clean enamel
Door	Temperate door		

Performance / Energy Label



Energy efficiency class	A	Energy consumption in forced air convection	7,00 MJ
Net volume of the cavity	60 litres	Energy consumption per cycle in fan-forced convection	1,94 kWh
Energy consumption per cycle in conventional mode	1,64 kWh	Number of cavities	1
Energy consumption in conventional mode	5,90 MJ	Energy efficiency index	95,6 %

Accessories Included



Chrome shelf with back and side stop	1	Grill mesh	1
Enamelled tray (20mm)	1	Telescopic Guide rails, partial Extraction	1
Extra deep enamelled tray (40mm)	1		

Electrical Connection

Voltage	220-240 V	Nominal power (W)	1900 W
Plug	No	Frequency (Hz)	50/60 Hz
Current	9 A	Power supply cable length	115 cm

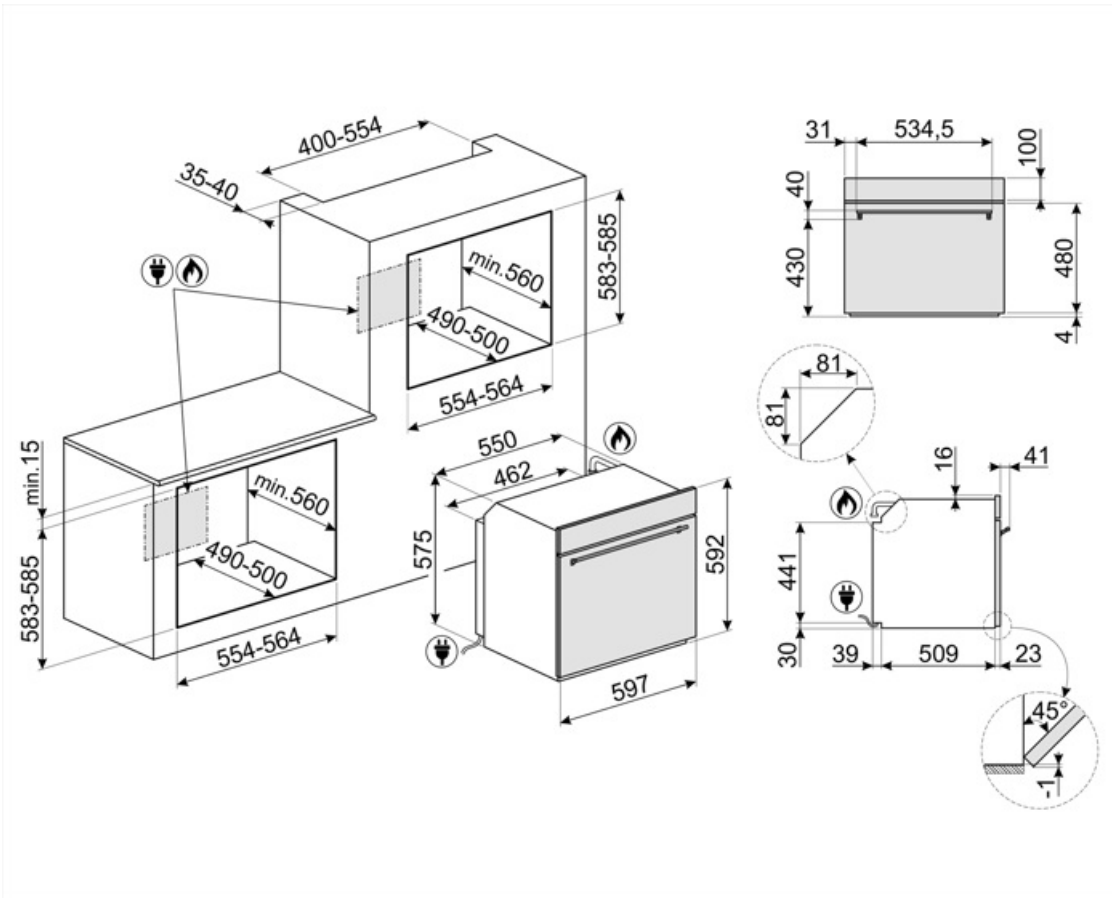

Compatible Accessories

BN620-1

Enamelled tray, 20mm deep



GTP

Partially extractable telescopic guides (1 level) Extraction: 300 mm Material: Stainless steel AISI 430 polished



PALPZ

Pizza shovel with fold away handle
width: 315mm length : 325mm



STONE2

Rectangular pizza stone without handles, suitable for 45cm and 60cm wide ovens. Dimensions W42 x H1.8 x D37.5cm. Ideal for cooking pizzas with the same results as a typical wood-fired oven. Can also be used for baking bread, focaccias and other recipes such as pies, flans or biscuits



BN640

Enamelled tray, 40mm deep



GTT

Totally extractable telescopic guides (1 level) Extraction: 433 mm Material: Stainless steel AISI 430 polished























PR3845X

Antifingerprint stainless steel. Cover for furniture in column installation of more ovens



Symbols glossary

 <p>A: Product drying performance, measured from A+++ to D / G depending on the product family</p>	 <p>Air cooling system: to ensure a safe surface temperatures.</p>
 <p>Triple glazed doors: Number of glazed doors.</p>	 <p>Enamel interior: The enamel interior of all Smeg ovens have a special antacid lining which helps keep the interior clean by reducing the amount of cooking grease adhering to it.</p>
 <p>Fingerprint proof stainless steel: Fingerprint proof stainless steel keeps stainless steel looking as good as new.</p>	 <p>Fan assisted base: the mix of fan and lower heating element alone allows to finish cooking foods already cooked on the surface but not internally more quickly. This system is recommended to finish cooking foods that are already well cooked on the surface, but not internally, which therefore require a moderate higher heat. Ideal for any type of food.</p>
 <p>Lower heating element only: This function is ideal for foods that require extra base temperature without browning, e.g. pastry dishes, pizza. Also suitable for slow cooking of stews and casseroles.</p>	 <p>Grill element: Using of grill gives excellent results when cooking meat of medium and small portions, especially when combined with a rotisserie (where possible). Also ideal for cooking sausages and bacon.</p>
 <p>Fan with grill element: The fan reduces the fierce heat from the grill, providing an excellent method of grilling various foods, chops, steaks, sausages etc. giving even browning and heat distribution, without drying out the food. The top two levels recommended for use, and the lower part of the oven can be used to keep items warm at the same time, an excellent facility when cooking a grilled breakfast. Half grill (centre portion only) is ideal for small quantities of food.</p>	 <p>Rotisserie with full grill: Rotisserie works in combination with a grill that provides an even browning of food.</p>
 <p>Fan + lower element + rotisserie: Circogas can also be used in conjunction with the rotisserie.</p>	 <p>Fan + grill element + rotisserie: this symbol adds the fan to the rotisserie to distribute the heat quickly and evenly.</p>
 <p>Rotisserie: The rotisserie (where installed) works in combination with the grill element to brown foods to perfection.</p>	 <p>Gas ovens offer instantaneous heat control, reduced cooking times and the ability to bake at much lower temperatures than electric ovens.</p>
 <p>All glass inner door: All glass inner door, a single flat surface which is simple to keep clean.</p>	 <p>The inner door glass: can be removed with a few quick movements for cleaning.</p>
 <p>Side lights: Two opposing side lights increase visibility inside the oven.</p>	 <p>The oven cavity has 4 different cooking levels.</p>
 <p>Telescopic rails: allow you to pull out the dish and check it without having to remove it from the oven entirely.</p>	 <p>The capacity indicates the amount of usable space in the oven cavity in litres.</p>
 <p>The capacity indicates the amount of usable space in the oven cavity in litres.</p>	