

# SFA4604VCNR

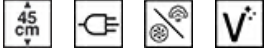

Category	45cm compact
Product Family	Oven
Power supply	Electric
Heat source	ELECTRICITY
Cooking method	Combi Steam
Cleaning system	Vapour Clean
EAN code	8017709251987



## Aesthetics

Aesthetic	Dolce Stil Novo	Glass Type	Eclipse
Colour	Black	Door	Full glass
Finishing	Glossy	Handle	Dolce Stil Novo
Design	Flat	Handle Colour	Black
Component finish	Copper	Logo	Applied
Material	Glass		

## Controls

	Display technology	TFT	No. of display languages	11
	Control setting	Full touch	Display languages	Italiano, English (UK), Français (FR), Nederlands, Español (ES), Português (PT), Svenska, Русский, Deutsch (DE), Dansk, English (AU)

## Programs / Functions

No. of cooking functions	14
Automatic programmes	50
Customisable recipes	10

### Traditional cooking functions

- |                     |                    |             |
|---------------------|--------------------|-------------|
| Static              | Fan assisted       | Circulaire  |
| Turbo               | Eco                | Large grill |
| Fan grill (large)   | Circulaire + grill | Base        |
| Fan assisted bottom |                    |             |

### Cooking functions with steam

- |                           |              |            |
|---------------------------|--------------|------------|
| Steam                     | Fan assisted | Circulaire |
| Warming and re-generation |              |            |

### Other Steam functions

- |                     |              |             |
|---------------------|--------------|-------------|
| Tank cleaning       | Water outlet | Water input |
| Descaling programme |              |             |

### Other functions

- |                 |                   |         |
|-----------------|-------------------|---------|
| Defrost by time | Defrost by weight | Proving |
| Sabbath         |                   |         |

### Cleaning functions

- |              |
|--------------|
| Vapour Clean |
|--------------|

## Options



- |                                     |                                       |                             |                      |
|-------------------------------------|---------------------------------------|-----------------------------|----------------------|
| <b>Time-setting options</b>         | Delay start and automatic end cooking | <b>Other options</b>        | Keep warm, Eco light |
| <b>Minute minder</b>                | Yes                                   | <b>Smart cooking</b>        | Yes                  |
| <b>Timer</b>                        | 1                                     | <b>Showroom demo option</b> | Yes                  |
| <b>Controls Lock / Child Safety</b> | Yes                                   | <b>Rapid pre-heating</b>    | Yes                  |

## Technical Features



- |                            |       |             |                |
|----------------------------|-------|-------------|----------------|
| <b>Minimum Temperature</b> | 30 °C | <b>Door</b> | Temperate door |
|----------------------------|-------|-------------|----------------|

<b>Maximum temperature</b>	250 °C	<b>Removable door</b>	Yes
<b>No. of shelves</b>	3	<b>Full glass inner door</b>	Yes
<b>No. of lights</b>	1	<b>Removable inner door</b>	Yes
<b>Light type</b>	Halogen	<b>Total no. of door glasses</b>	3
<b>User-replaceable light</b>	Yes	<b>Soft Close hinges</b>	Yes
<b>Light Power</b>	40 W	<b>Cooling system</b>	Tangential
<b>Light when door is opened</b>	Yes	<b>Cooling duct</b>	Single
<b>Lower heating element power</b>	1000 W	<b>Usable cavity space dimensions (HxWxD)</b>	212x462x407 mm
<b>Grill element - power</b>	2000 W	<b>Temperature control</b>	Electronic
<b>Circular heating element - Power</b>	1400 W	<b>Cavity material</b>	Ever clean Enamel
<b>Heating suspended when door is opened</b>	Yes	<b>Water loading</b>	Fill&Hide, automatic
<b>Boiler - Power</b>	900 W	<b>Tank capacity</b>	1,2 l
<b>Door opening type</b>	Standard opening	<b>Steam stops when door is opened</b>	Yes

## Performance / Energy Label



<b>Energy efficiency class</b>	A+	<b>Energy consumption in forced air convection</b>	2.12 MJ
<b>Net volume of the cavity</b>	41 l	<b>Energy consumption per cycle in fan-forced convection</b>	0.59 kWh
<b>Energy consumption per cycle in conventional mode</b>	0.85 kWh	<b>Number of cavities</b>	1
<b>Energy consumption in conventional mode</b>	3.06 MJ	<b>Energy efficiency index</b>	81,9 %

## Accessories Included



<b>Rack with back stop</b>	1	<b>St/steel perforated deep tray (40mm)</b>	1
<b>Enamelled deep tray (40mm)</b>	1	<b>Telescopic Guide rails, total Extraction</b>	1
<b>Insert gird</b>	1	<b>Other</b>	Sponge/ Boiler cover/ Beaker
<b>St/steel tray (20mm)</b>	1		

## Electrical Connection

<b>Plug</b>	(I) Australia	<b>Nominal power</b>	3100 W
<b>Voltage</b>	220-240 V	<b>Frequency (Hz)</b>	50/60 Hz
<b>Current</b>	14 A	<b>Power supply cable length</b>	115 cm

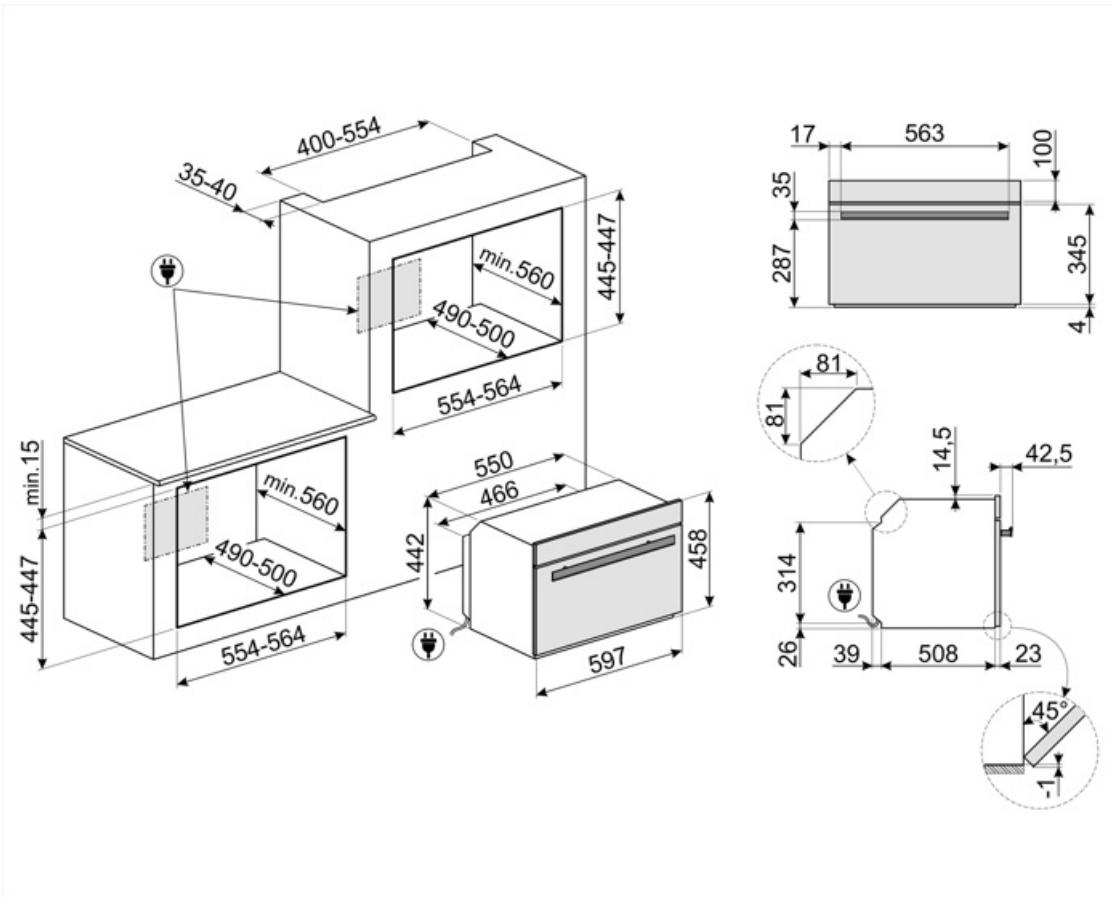

---

## Not included accessories

---

### BN620-1

Enamelled tray, 20mm deep



### PALPZ

Pizza shovel with fold away handle  
width: 315mm length : 325mm



### PR3845X

Antifingerprint stainless steel. Cover for  
furniture in column installation of more  
ovens



### BN640

Enamelled tray, 40mm deep



### PR3845N

Black cover for furniture when more  
ovens are installed in column









































### PRTX

Refractory pizza stone with handles.  
D=35cm Not suitable for microwave  
ovens. Suitable for gas ovens, to be  
put on the griddle.



## Symbols glossary (TT)

 <p>Child lock: some models are fitted with a device to lock the programme/cycle so it cannot be accidentally changed.</p>	 <p>A+: Energy efficiency class A+ helps to save up to 10% energy compared to class A. Maximum performance with minimum consumption is guaranteed.</p>
 <p>Combination steam: ovens can be used either as a steam oven, or as a traditional oven, or alternatively the two methods can be combined.</p>	 <p>Air cooling system: to ensure a safe surface temperatures.</p>
 <p>Defrost by time: with this function the time of thawing of foods are determined automatically.</p>	 <p>Defrost by weight: With this function the defrosting time is determined</p>
 <p>Descaling function: Is essential to remove excess deposits of limestone in the tank and allow the proper operation of the product. The need to perform this operation is signaled by the product itself.</p>	 <p>Triple glazed doors: Number of glazed doors.</p>
 <p>Automatic lighting switches off: for greater energy savings, the lighting switches off automatically after one minute from the start of cooking.</p>	 <p>Electric</p>
 <p>Enamel interior: The enamel interior of all Smeg ovens have a special antacid lining which helps keep the interior clean by reducing the amount of cooking grease adhering to it.</p>	 <p>Fan assisted base: the mix of fan and lower heating element alone allows to finish cooking foods already cooked on the surface but not internally more quickly. This system is recommended to finish cooking foods that are already well cooked on the surface, but not internally, which therefore require a moderate higher heat. Ideal for any type of food.</p>
 <p>Fan with upper and lower elements: The elements combined with the fan aim to provide more uniform heat, a similar method to conventional cooking, so pre-heat is required. Most suitable for items requiring slow cooking methods.</p>	 <p>Upper and lower element only: a traditional cooking method best suited for single items located in the centre of the oven. the top pf the oven will always be hottest. Ideal for roast, fruit cakes, bread etc.</p>
 <p>Lower heating element only: This function is ideal for foods that require extra base temperature without browning, e.g. pastry dishes, pizza. Also suitable for slow cooking of stews and casseroles.</p>	 <p>Circulaire + grill: Circulaire with upper element or grill: Similar to fan with upper element with the added cooking speed of circulaire, ideal for dishes with a crispy topping. When used with the grill the food will brown more quickly.</p>
 <p>Circulaire: The combination of the fan and circular element around it gives a hot air cooking method. This provides many benefits including no preheat if cook time is more than 20 minutes, no flavour transfer when cooking different foods at the same time, less energy, and shorter cook times. Good for all types of food.</p>	 <p>ECO: The combination of the grill, fan and lower element is particularly suitable for cooking small quantities of food.</p>

- |  |  |
|--|--|
|  <p><b>Grill element:</b> Using of grill gives excellent results when cooking meat of medium and small portions, especially when combined with a rotisserie (where possible). Also ideal for cooking sausages and bacon.</p>   |  <p><b>Fan with grill element:</b> The fan reduces the fierce heat from the grill, providing an excellent method of grilling various foods, chops, steaks, sausages etc. giving even browning and heat distribution, without drying out the food. The top two levels recommended for use, and the lower part of the oven can be used to keep items warm at the same time, an excellent facility when cooking a grilled breakfast. Half grill (centre portion only) is ideal for small quantities of food.</p> |
|  <p><b>Steam cooking:</b> it's a natural way of cooking for any kind of products, from vegetables to desserts, to preserve the nutritional and organoleptic properties of ingredients. Ideal for cooking without fat, to heat up food without drying. Steam is ideal for simultaneous cooking of meals that require different cooking times.</p> |  <p><b>Fan combined with traditional cooking,</b> where heat is generated from above and below, provides uniform heat. Adding the steam function allows the same cooking results in less time.</p>  |
|  <p><b>Circulaire element with steam:</b> Cooking with the simultaneous use of the circular heating element in combination with fan and steam supply.</p>  |  <p>FUN_STEAM_OTHER_WATER_IN_OUT_72dpi</p>  |
|  <p><b>Reheat:</b> This function can reheat precooked dishes, without becoming dry or hard.</p>   |  <p><b>Circulaire with upper and lower elements:</b> The use of the fan with both elements allows food to be cooked quickly and effectively, ideal for large joints that require thorough cooking. It offers a similar result to rotisserie, moving the heat around the food, instead of moving the food itself, enabling any size or shape to be cooked.</p>  |
|  <p><b>Compact appliances with a height of 45 cm -</b> perfect solution to meet the functional requirements of kitchen sets of small height. Available in several types and in different styles.</p>   |  <p><b>All glass inner door:</b> All glass inner door, a single flat surface which is simple to keep clean.</p>   |
|  <p><b>The inner door glass:</b> can be removed with a few quick movements for cleaning.</p>   |  <p>KEEP_WARM_72dpi</p>   |
|  <p><b>Side lights:</b> Two opposing side lights increase visibility inside the oven.</p>  |  <p><b>ECO-logic:</b> option allows you to restrict the power limit of the appliance real energy saving.</p>  |
|  <p><b>Air at 40°C</b> provides the perfect environment for proving yeast type dough mixes. Simply select the function and place dough in the cavity for allotted</p>  |  <p><b>Rapid preheat:</b> The rapid preheat function can be used to reach the selected temperature in just a few minutes.</p>   |
|  <p><b>Sabbath:</b> This function allows you to cook food during the Sabbath, the Holiday of rest in the Jewish religion, respecting the precepts. The oven works</p>  |  <p>The oven cavity has 3 different cooking levels.</p>   |
|  <p><b>Smart Cooking System:</b> for the perfect cooking it is simply necessary choosing the kind and the weight of food and the cooking temperature: any other setting will be established automatically.</p>   |  <p><b>Soft close:</b> all models are equipped with advanced function of smooth closing of the door, which allows the device to close smoothly and quietly.</p>   |



To guarantee the optimal functioning of the appliance, it is suggested to carry out the tank cleaning roughly once every 2-3 months.



Telescopic rails: allow you to pull out the dish and check it without having to remove it from the oven entirely.



Electronic control: Allows you to maintain temperature inside the oven with the precision 2-3 ° C. This enables to cook meals that are very sensitive to temperature changes, such as cakes, souffles, puddings.



Touch controls: Easy to use touch controls allow the appliance to be programmed at the touch of a button.



Vapour Clean: a simple cleaning function using steam to loosen deposits in the oven cavity.



The capacity indicates the amount of usable space in the oven cavity in litres.