

SO4102S3B3



| | |
|------------------------|---------------|
| Category | 45cm compact |
| Product Family | Oven |
| Vitality system | Yes |
| Power supply | Electric |
| Heat source | Electric |
| Cooking method | Combi Steam |
| Galileo cavity | Steam100 |
| Cleaning system | Vapor Clean |
| EAN code | 8017709325619 |



Aesthetics

| | | | |
|--------------------------|--------|------------------------|---------------|
| Aesthetics | Linea | Serigraphy type | Symbols |
| Colour | Black | Door | Full glass |
| Finishing | Gloss | Handle | Linea minimal |
| Design | Flat | Handle Colour | Black |
| Material | Glass | Logo | Silk screen |
| Glass Type | Clear1 | Controls colour | Matt black |
| Serigraphy colour | Grey | | |

Controls



| | | | |
|---------------------------|-----------|------------------------|---------------|
| Display name | EvoScreen | Control setting | Touch control |
| Display technology | LCD | | |

Programs / Functions

| | |
|---------------------------------|----|
| No. of cooking functions | 12 |
|---------------------------------|----|

Traditional cooking functions



Static



Fan assisted



Circulaire



Turbo (circulaire + bottom + upper + fan)



ECO



Large grill



Base



Pizza

Cooking functions with steam



Manual steam



Steam + bottom + upper + fan



Steam + circulaire + fan



Sous Vide

Other Steam functions



Tank cleaning



Water outlet



Water input



Descaling

Other functions



Defrost by time



Proving



Stone cooking



BBQ



Air-Fry



Sabbath

Cleaning functions



Vapor Clean

Options



Time-setting options

Delay start and automatic end cooking

Minute minder
Timer

Yes
1

Other options

Keep warm, Eco light, Brightness, Tones

Showroom demo option
Rapid pre-heating

Yes
Yes

Technical Features



| | | | |
|--|------------------|---|-------------------|
| Minimum Temperature | 30 °C | Full glass inner door | Yes |
| Maximum temperature | 250 °C | Removable inner door | Yes |
| Shelf positions | 2 | Total no. of door glasses | 3 |
| No. of lights | 1 | Soft Close hinges | Yes |
| Light type | Halogen | Soft Open | Yes |
| User-replaceable light | Yes | Chimney | Variable |
| Light power | 40 W | Cooling system | Tangential |
| Light when door is opened | Yes | Cooling duct | Single |
| Lower heating element power | 1200 W | Steam range | 20 - 100% |
| Grill element - power | 1800 W | Usable cavity space dimensions (HxWxD) | 211x462x401 mm |
| Circular heating element - Power | 2000 W | Temperature control | Electronic |
| Heating suspended when door is opened | Yes | Cavity material | Easy clean enamel |
| Door opening type | Standard opening | Water loading | Drawer, manual |
| Door | Temperate door | Tank capacity | 0,8 l |
| Removable door | Yes | | |

Performance / Energy Label



| | | | |
|--|-----------|--|----------|
| Energy efficiency class | A++ | Energy consumption in forced air convection | 1.58 MJ |
| Net volume of the cavity | 41 litres | Energy consumption per cycle in fan-forced convection | 0.44 kWh |
| Energy consumption per cycle in conventional mode | 0.80 kWh | Number of cavities | 1 |
| Energy consumption in conventional mode | 2.88 MJ | Energy efficiency index | 61,1 % |

Accessories Included

| | | | |
|-----------------------------------|---|---|-------------------|
| Chrome shelf | 1 | St/steel tray (20mm) | 1 |
| Enamelled deep tray (50mm) | 1 | St/steel perforated deep tray (40mm) | 1 |
| Grill mesh | 1 | Other | water loading kit |

Electrical Connection

| | | | |
|--------------------------|-----------|----------------------------------|----------|
| Voltage | 220-240 V | Frequency (Hz) | 50/60 Hz |
| Current | 13 A | Power supply cable length | 150 cm |
| Nominal power (W) | 3000 W | | |

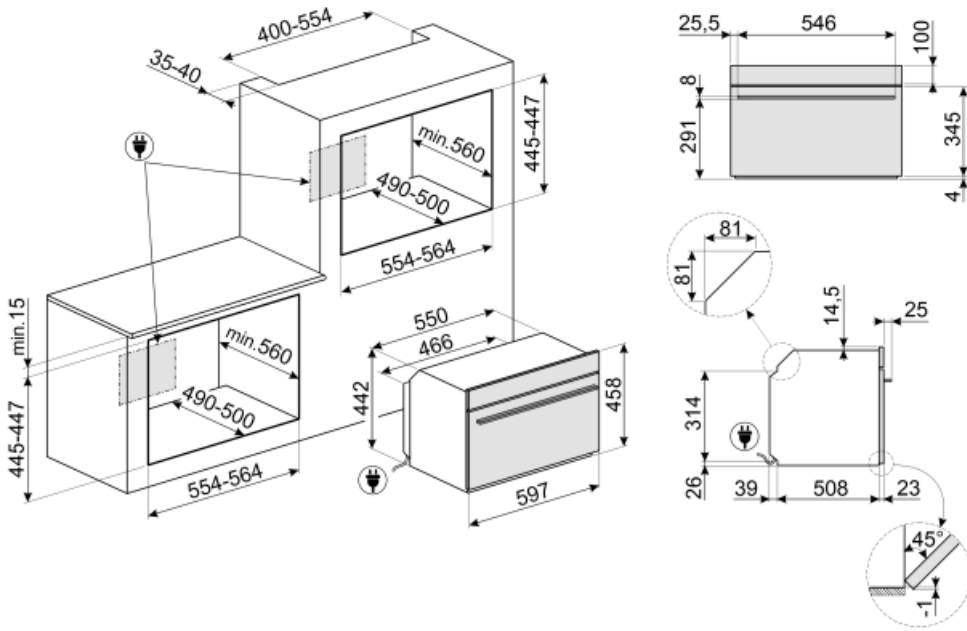

Not included accessories

AIRFRY

Air fryer rack AIRFRY . Ideal for recreating traditional frying in the oven, but with fewer calories and less fat. It allows you to cook quickly and simply dishes such as French fries, fried vegetables and fish, ensuring perfect browning and crispiness.



PR3845X

Antifingerprint stainless steel. Cover for furniture in column installation of more ovens



BX640PL

Stainless steel perforated tray. To cook many types of vegetables, fish, white meats, ravioli or other varieties of stuffed pasta, preserving all the vitamins and mineral salts for a richer, fuller and natural flavour



BN620-1

Enamelled tray, 20mm deep



BBQ

Double sided plate BBQ. Suitable for recreating succulent and crispy dishes in the oven with the typical taste of grilled cooking. The ribbed side is particularly suitable for meats and cheeses. The smooth side for fish, seafood and vegetables.



BN640

Enamelled tray, 40mm deep



GTP2

Partially extractable telescopic guides (1 level), suitable for traditional ovens. Made in stainless steel, they guarantee stability and facilitate the smooth extraction of the trays.



PRTX

Refractory pizza stone with handles. D=35cm Not suitable for microwave ovens. Suitable for gas ovens, to be put on the griddle.



ET50

Enamelled tray, 50mm deep



ET20

Enamelled tray, 20mm deep



PALPZ

Pizza shovel with fold away handle width: 315mm length : 325mm



















GTTV2

Totally extractable telescopic guides (1 level), suitable for steam ovens. Made in stainless steel, they guarantee stability and facilitate the smooth extraction of the trays.





Symbols glossary

| | |
|--|---|
|  <p>A++: Energy efficiency class A++ helps to save up to 20% energy compared to class A. Maximum performance with minimum consumption is guaranteed.</p> |  <p>Combination steam: ovens can be used either as a steam oven, or as a traditional oven, or alternatively the two methods can be combined.</p> |
|  <p>Air cooling system: to ensure a safe surface temperatures.</p> |  <p>Defrost by time: with this function the time of thawing of foods are determined automatically.</p> |
|  <p>Descaling function: Is essential to remove excess deposits of limestone in the tank and allow the proper operation of the product. The need to perform this operation is signaled by the product itself.</p> |  <p>Triple glazed doors: Number of glazed doors.</p> |
|  <p>Automatic lighting switches off: for greater energy savings, the lighting switches off automatically after one minute from the start of cooking.</p> |  <p>Electric</p> |
|  <p>Enamel interior: The enamel interior of all Smeg ovens have a special antacid lining which helps keep the interior clean by reducing the amount of cooking grease adhering to it.</p> |  <p>Fan with upper and lower elements: The elements combined with the fan aim to provide more uniform heat, a similar method to conventional cooking, so pre-heat is required. Most suitable for items requiring slow cooking methods.</p> |
|  <p>Upper and lower element only: a traditional cooking method best suited for single items located in the centre of the oven. the top pf the oven will always be hottest. Ideal for roast, fruit cakes, bread etc.</p> |  <p>Lower heating element only: This function is ideal for foods that require extra base temperature without browning, e.g. pastry dishes, pizza. Also suitable for slow cooking of stews and casseroles.</p> |
|  <p>Circulaire: The combination of the fan and circular element around it gives a hot air cooking method. This provides many benefits including no preheat if cook time is more than 20 minutes, no flavour transfer when cooking different foods at the same time, less energy, and shorter cook times. Good for all types of food.</p> |  <p>ECO: The combination of the grill, fan and lower element is particularly suitable for cooking small quantities of food.</p> |
|  <p>Grill element: Using of grill gives excellent results when cooking meat of medium and small portions, especially when combined with a rotisserie (where possible). Also ideal for cooking sausages and bacon.</p> |  <p>Pizza function: The simultaneous operation of three elements ensures an optimum cooking facility when used with the Smeg pizza stone.</p> |

- 

Sous Vide Cooking: Steam function for perfect cooking of sous vide dishes. Enhances the taste of dishes and keeps their appearance and nutrients unaltered. Vacuum cooking (Sous Vide) made with the help of a steam oven is also an incredibly healthy and genuine type of cooking. The Sous Vide cooking technique allows heat to be efficiently transferred from the steam to the food, avoiding the loss of flavour due to oxidation and the evaporation of nutrients and moisture during cooking. Sous Vide cooking also allows better control over the cooking of food compared to traditional methods, ensuring uniform cooking results. It also allows cooking at a lower temperature than traditional cooking.



Steam cooking: it's a natural way of cooking for any kind of products, from vegetables to desserts, to preserve the nutritional and organoleptic properties of ingredients. Ideal for cooking without fat, to heat up food without drying. Steam is ideal for simultaneous cooking of meals that require different cooking times.
- 

Fan combined with traditional cooking, where heat is generated from above and below, provides uniform heat. Adding the steam function allows the same cooking results in less time.



Circulaire element with steam: Cooking with the simultaneous use of the circular heating element in combination with fan and steam supply.
- 

FUN_STEAM_OTHER_WATER_IN_OUT_72dpi



Circulaire with upper and lower elements: The use of the fan with both elements allows food to be cooked quickly and effectively, ideal for large joints that require thorough cooking. It offers a similar result to rotisserie, moving the heat around the food, instead of moving the food itself, enabling any size or shape to be cooked.
- 

Compact appliances with a height of 45 cm - perfect solution to meet the functional requirements of kitchen sets of small height. Available in several types and in different styles.



All glass inner door: All glass inner door, a single flat surface which is simple to keep clean.
- 

The inner door glass: can be removed with a few quick movements for cleaning.



Keep warm: This function allows you to keep precooked foods warm.
- 

Side lights: Two opposing side lights increase visibility inside the oven.



Air at 40°C provides the perfect environment for proving yeast type dough mixes. Simply select the function and place dough in the cavity for allotted
- 

Rapid preheat: The rapid preheat function can be used to reach the selected temperature in just a few minutes.



Sabbath: This function allows you to cook food whilst respecting the provisions of the Jewish day of rest.
- 

The oven cavity has 2 different cooking levels.











Soft close: all models are equipped with advanced function of smooth closing of the door, which allows the device to close smoothly and quietly.
- 

To guarantee the optimal functioning of the appliance, it is suggested to carry out the tank cleaning roughly once every 2-3 months.



Electronic control: Allows you to maintain temperature inside the oven with the precision 2-3 ° C. This enables to cook meals that are very sensitive to temperature changes, such as cakes, souffles, puddings.

-
- | | |
|---|---|
|  <p>Touch controls: Easy to use touch controls allow the appliance to be programmed at the touch of a button.</p> |  <p>Vapor Clean: a simple cleaning function using steam to loosen deposits in the oven cavity.</p> |
|  <p>The capacity indicates the amount of usable space in the oven cavity in litres.</p> |  <p>...</p> |
|  <p>Manual water loading system: It is possible to load the tank in less than 40 seconds. The loading is done manually thanks to a special funnel included.</p> |  <p>Dedicated cooking function for the double sided plate BBQ. Suitable for recreating succulent and crispy dishes in the oven with the typical taste of g</p> |
|  <p>Dedicated cooking function for the Air fryer rack AIRFRY . Ideal for recreating traditional frying in the oven, but with fewer calories and less fat.</p> |  <p>Dedicated cooking function for the rectangular refractory stone PPR2 Dimensions Ideal for cooking pizzas with the same results as a typical wood-fire</p> |