

SO5100TB3



Categorie	75 cm
Product familie	Oven
Stroomvoorziening	Elektrisch
Warmtebron	Elektriciteit
Bereidingswijze	Multifunctionele oven
Reinigingssysteem	Vapor Clean reiniging
EAN-code	8017709327125



Design

Design	Linea	Deur	Geheel glas
Kleur	Zwart	Handvat	Linea minimal
Design	Plat	Kleur handvat	Zwart
Materiaal	Glas	Logo	Geëtt
Type glas	Clear1	Bedieningsknoppen	Linea
Kleur serigrafie	Grijs	Kleur bedieningsknoppen	Mat zwart
Type zeefdruk	Symbolen		









Bediening

			
Display	DigiScreen	Bediening	Knobs & touch buttons
Display	LED display	Aantal bedieningsknoppen	2

Programma's / Functies

Aantal kookfuncties	8
Automatische programma's	No
Individualiseerbare recepten	No

Traditionele bereidingsfuncties

 Statisch	 Statisch + ventilator	 Circulatie (ventilator + circulaire)
 Turbo: ventilator + circulaire + statisch	 ECO	 Grote grill
 Ventilator + grote grill	 Onderwarmte	

Overige functies

 Ontdooien op tijd























Reinigingsfuncties

 Vapor Clean reiniging

Opties

Tijdsinstelling	Automatische in- en uitschakeling	Timer	1
Timer	Ja		

Technische specificaties

																					
Inhoud (l)	Cavity	Minimum temperatuur	Maximum temperatuur	Aantal kookniveaus	Dubbele ventilator	Aantal lampen	Type lamp	User-replaceable light	Vermogen lamp	Verlichting bij opening deur	Onderwarmte - vermogen	Circulatie - vermogen	Warmte onderbroken bij openen deur	Opening deur	Deur	Uitneembare ovendeur	Volledig glazen binnendeur	Uitneembaar glas binnendeur	Totaal aantal ruiten	Koelsysteem	Koelleiding
77 l	QS-Galileo	30 °C	260 °C	4	1	1	Halogeen	Ja	40 W	Ja	1600 W	2000 W	Ja	Standaard opening	Temperatuur gecontroleerde deur	Ja	Ja	Ja	3	Mantelkoeling	Dubbel

Bovenwarmte - vermogen	1200 W	Reductie snelheid koelsysteem	Ja
Grill - vermogen	1500 W	Afmetingen bruikbare interne ovenruimte (hxbxd)	312x613x402 mm
Grote vlakgrill - vermogen	2700 W	Temperatuurcontrole	Elektronisch
		Materiaal ovenruimte	Ever Clean emaille

Prestaties / energielabel



Energie-efficiëntieklasse	A+	Energy consumption in forced air convection	2,56 MJ
Netto volume	77 l	Energieconsumptie in turbo functie	0,71 kWh
Energieconsumptie in conventionele functie	1,24 kWh	Aantal ovens	1
Energy consumption in conventional mode	4,46 MJ	Energie-efficiëntie Index	81,6 %

Meegeleverde accessoires

Ovenrooster met stop	1	Bakplaat (40 mm)	1
----------------------	---	------------------	---

Elektrische aansluiting

Spanning	220-240 V	Nominale aansluitwaarde	3100 W
Stekker	Nee	Frequentie	50/60 Hz
Stroom	14 A	Lengte voedingskabel	150 cm

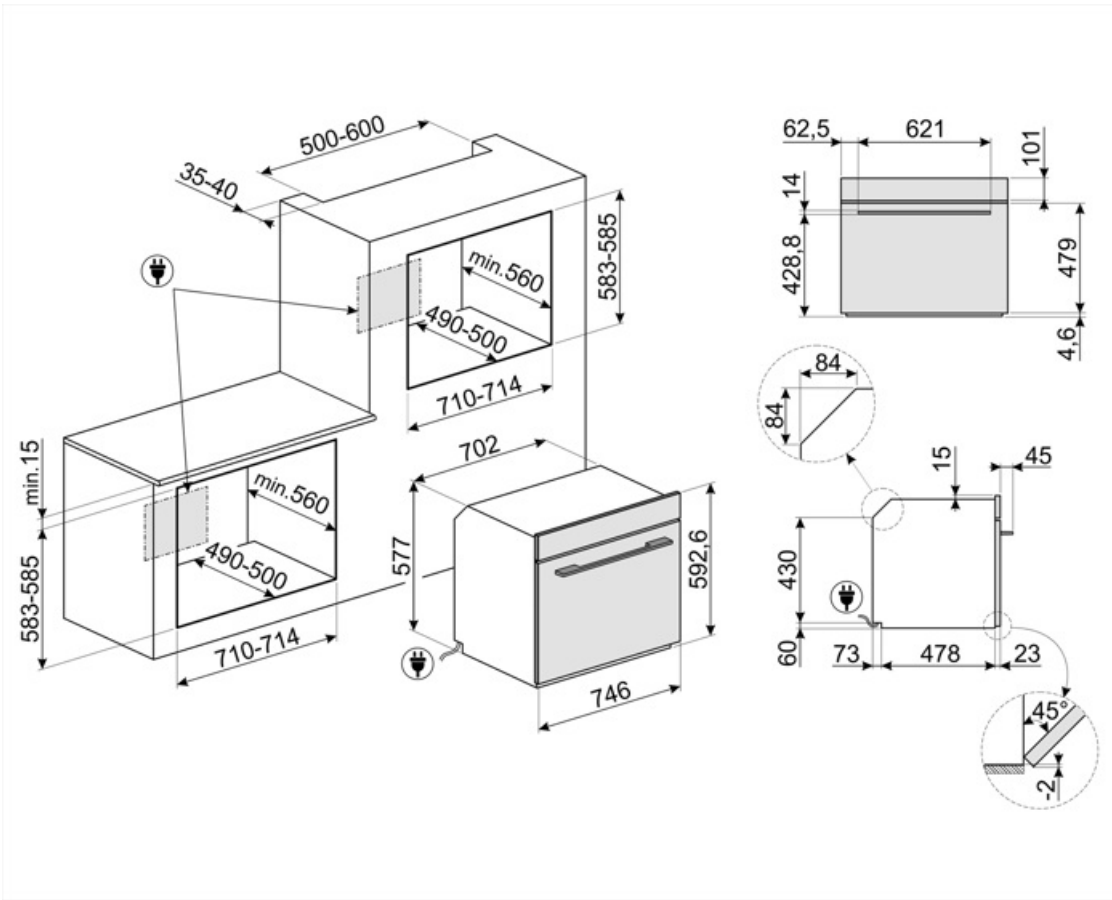















Compatible Accessories









STONE

Rectangular refractory stone Ideal for cooking pizzas with the same results as a typical wood-fired oven. Can also be used for baking bread, focaccias and other recipes such as pies, flans or biscuits Dimensions:L42 x H1,8 x P37,5 cm.



Symbols glossary

 <p>A+: Energy efficiency class A+ helps to save up to 10% energy compared to class A. Maximum performance with minimum consumption is guaranteed.</p>	 <p>Air cooling system: to ensure a safe surface temperatures.</p>
 <p>Defrost by time: Manual defrost function. At the end of the set duration, the function stops.</p>	 <p>Triple glazed doors: Number of glazed doors.</p>
 <p>Elektrische aansluiting</p>	 <p>Ever Clean Enamel: Ever Clean enamel is applied electrostatically, corner to corner and edge to edge to prevent cracking or cracks over time. It is a particular pyrolytic enamel, resistant to acids which, in addition to being pleasantly bright, promotes greater cleaning of the oven walls, thanks to its lower porosity. It is baked at over 850 °C and slowly polymerized at a scientifically determined rate to ensure uniform depth and strength. Ever Clean enamel creates an impeccable finish both on the inside of the oven and on the trays, making the surfaces of the oven incredibly easy to maintain over time as it reduces the adhesion of fat during cooking.</p>
 <p>Ventilator met bovenste en onderste elementen: De elementen in combinatie met de ventilator zijn bedoeld om een meer gelijkmatige warmte te bieden, een methode die vergelijkbaar is met conventioneel koken, dus voorverwarmen is vereist. Het meest geschikt voor items die langzaam koken vereisen.</p>	 <p>Alleen boven- en onder element: een traditionele kookmethode die het meest geschikt is voor losse items in het midden van de oven. de bovenkant van de oven zal altijd het heetst zijn. Ideaal voor gebraden vlees, fruitcake, brood etc.</p>
 <p>Base: the heat comes only from the bottom of the cavity. The fan is not active. Ideal for sweet and savory pies, cobblers and pizzas. Designed to complete cooking and make food more crunchy. This symbol in gas ovens indicates the gas burner.</p>	 <p>Circulaire: De combinatie van de ventilator en het ronde element eromheen zorgt voor een hete lucht kookmethode. Dit biedt vele voordelen, waaronder geen voorverwarmen als de kooktijd meer dan 20 minuten bedraagt, geen smaakoverdracht bij het gelijktijdig bereiden van verschillende soorten voedsel, minder energie en kortere kooktijden. Geschikt voor alle soorten voedsel.</p>
 <p>De combinatie van de grill, de ventilator en onderwarmte is interessant voor het bereiden van kleine hoeveelheden.</p>	 <p>Grill: Very intense heat coming only from above from a double heating element. The fan is not active. Provides excellent grilling and gratinating results. Used at the end of cooking, it gives a uniform browning to dishes.</p>
 <p>Fan grill: very intense heat coming only from above from a double heating element. The fan is active. It allows the optimal grilling of thickest meats. Ideal for large cuts of meat.</p>	 <p>Circulaire met bovenste en onderste elementen: door het gebruik van de ventilator met beide elementen kan voedsel snel en effectief worden gekookt, ideaal voor grote stukken vlees die grondig moeten worden gekookt. Het biedt een vergelijkbaar resultaat als rotisserie, waarbij de warmte rond het voedsel wordt verplaatst in plaats van het voedsel zelf te verplaatsen, waardoor elke maat of vorm kan worden gekookt.</p>

-
- | | |
|---|--|
|  All glass inner door: All glass inner door, a single flat surface which is simple to keep clean. |  The inner door glass: can be removed with a few quick movements for cleaning. |
|  Side lights: Two opposing side lights increase visibility inside the oven. |  The oven cavity has 4 different cooking levels. |
|  Electronic control: Allows you to maintain temperature inside the oven with the precision 2-3 ° C. This enables to cook meals that are very sensitive to temperature changes, such as cakes, souffles, puddings. |  Vapor Clean: a simple cleaning function using steam to loosen deposits in the oven cavity. |
|  The capacity indicates the amount of usable space in the oven cavity in litres. |  The capacity indicates the amount of usable space in the oven cavity in litres. |
|  DIGI screen display + bedieningsknoppen | |