

SO6606WAPNR



Categorie	60 cm
Product familie	Oven
Vitality system	Ja
Stroomvoorziening	Elektrisch
Bereidingswijze	Multitech
Galileo technologie	Omnichef
Reinigingsysteem	Vapor Clean reiniging
EAN-code	8017709292423



Design

Design	Dolce Stil Novo	Type glas	Eclipse zwart glas
Kleur	Zwart	Deur	Geheel glas
Afwerking	Glanzend	Handvat	Dolce Stil Novo
Design	Plat	Kleur handvat	Zwart
Afwerking componenten	Koper afwerking	Logo	Geassembleerd
Materiaal	Glas		

Bediening



Display	VivoScreen max	Aantal talen display	20
Display	Touch display	Display talen	Italiano, English (UK), Français (FR), Français (CA), Nederlands, Español (ES), Español (MX), Português (PT), Svenska, Русский, Deutsch (DE), Dansk, Norsk, Polski, English (AU), Suomi, Ukrainian, Kazakh, Afrikaans (ZA), Zulu (ZA)
Bediening	Geavanceerde touch display		

Programma's / Functies

Aantal kookfuncties	26
Automatische programma's	150
Levels stoompulsen	3 + manual

**Individualiseerbare recepten
Traditionele bereidingsfuncties**

10

 Statisch

 Statisch + ventilator



Circulatie (ventilator + circulaire)



Turbo: ventilator + circulaire +
statisch

 ECO



Grote grill

 Ventilator + grote grill

 Onderwarmte



Circulaire + onderwarmte

 Pizza

Functies met stoempulsen



Statisch + ventilator met
stoempulsen



Circulaire + onderwarmte +
stoempulsen



Circulaire + stoempulsen

 Turbo + stoempulsen



Ventilator + grill + stoempulsen

Bereidingsfuncties met stoom



Stoom



Stoom + onder-en bovenwarmte +
ventilator



Stoom + circulaire + ventilator

Circulaire + onderwarmte



Sous-vide

Andere stoomfuncties



Reiniging reservoir







Water afvoer



Water toevoer

 Ontkalking

Bereidingsfuncties met microgolven

 Microgolfoven	 Microgolf + boven- en onderwarmte + ventilator	 Microgolf + circulaire + ventilator
 Microgolf + grill	Microgolf + Circulaire + Onderwarmte	

Bereidingsfuncties met microgolven

Multitech

Twintech











Overige functies

 Ontdooien op tijd	 Ontdooien op gewicht	 Rijzen
 Stone cooking	 BBQ	 Air-Fry
 Melt	 Soft	 Pop-corn
 Warmhouden	 Bordenwarmfunctie	 Sabbath

Reinigingsfuncties

 Vapor Clean reiniging
--

Opties

									
Tijdsinstelling	Automatische in- en uitschakeling	Same Time cooking	Ja	DeltaT cooking	Ja	Showroom demo optie	Ja	Begeleide demo functie	Ja
Timer	Ja	Snelgids	Ja	Chronologie	Ja, de 10 laatst gebruikte functies	Snel voorverwarmen	Ja	Instant GO	Ja
Timer	3								
Kinderbeveiliging	Ja								
Andere opties	Warmhoudfunctie, Eco light, Taalinstelling, Weergave digitale klok, Geluiden, Helderheid, Volume geluiden								
Koken met temperatuursonde	Ja								

Multi-step cooking	Tot 3 stappen instelbaar
Smart cooking	Ja

Technische specificaties



Inhoud (l)	68 l	Deur	Koud
Cavity	QS-Galileo	Volledig glazen binnendeur	Ja
Minimum temperatuur	25 °C	Totaal aantal ruiten	4
Maximum temperatuur	250 °C	Soft Close scharnieren	Ja
Aantal kookniveaus	5	Soft open & close scharnieren	Ja
Dubbele ventilator	1	Inverter technologie	Ja
Aantal lampen	2	Stirrer	Ja
Type lamp	multilevel LED	Chimney	Double
Vermogen lamp	5 W	Koelsysteem	Centrifugal
Verlichting bij opening deur	Ja	Koelleiding	Dubbel
Onderwarmte - vermogen	1200 W	Reductie snelheid koelsysteem	Ja
Bovenwarmte - vermogen	1000 W	Hoeveelheid stoom	20 - 100%
Grill - vermogen	1700 W	Afmetingen bruikbare interne ovenruimte (hxbxd)	353x470x397 mm
Grote vlakgrill - vermogen	2700 W	Temperatuurcontrole	Elektronisch
Circulatie - vermogen	2000 W	Materiaal ovenruimte	Ever Clean emaille
Warmte onderbroken bij openen deur	Ja	Water toevoer	Automatische Fill & Hide
Opening deur	Standaard opening	Capaciteit reservoir	2 l

Prestaties / energielabel



Netto volume	68 l	Effectief vermogen microgolf	900 W
Aantal ovens	1		

Meegeleverde accessoires



Luxury rack (inox)	2	Diepe geperforeerde inox ovenschaal (40 mm)	1
Geëmailleerde diepe ovenschaal (50 mm)	1	Glazen ovenplaat	1
Inzetrooster	1	Telescopische geleiders, volledig uitschuifbaar	1
Inox ovenschaal (20 mm)	1	Temperatuur sonde	Ja, driepunt temperatuursonde

Elektrische aansluiting

Spanning 220-240 V
 Stekker Nee
 Stroom 13 A

Nominale aansluitwaarde 3000 W
 Frequentie 50/60 Hz
 Lengte voedingskabel 150 cm

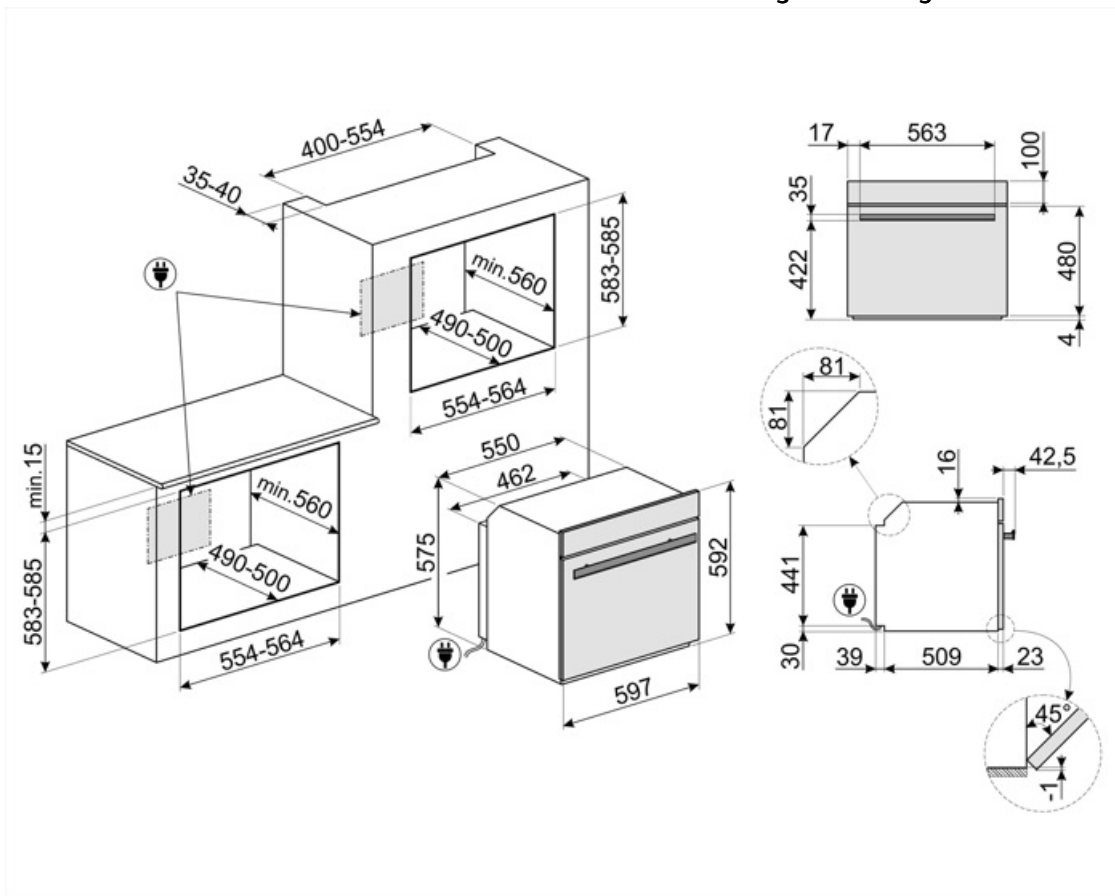

Compatible Accessories

AIRFRY



BBQ

Dubbelzijdig



BX640P

Inox geperforeerde schaal voor stoomoven, H 40 x D 455 x D 176 mm



ET20

Geëmailleerde ovenschaal voor 45cm en 60cm ovens. Diepte 20 mm.



GTP2

Partially extractable telescopic guides (1 level), suitable for traditional ovens. Made in stainless steel, they guarantee stability and facilitate the smooth extraction of the trays.



GTTV2

Volledig uitschuifbare telescopische rails (1 niveau) voor (stoom-)ovens (SO-).



PR3845N

Black cover for furniture when more ovens are installed in column



AIRFRY2

Air fryer tray. Ideal for recreating traditional frying in the oven, but with fewer calories and less fat. It allows you to cook quickly and simply dishes such as French fries, fried vegetables and fish, ensuring perfect browning and crispiness.



BX640

Inox schaal voor stoomoven, H 40 x B 455 x D 176 mm



BX640PL

Stainless steel perforated tray. To cook many types of vegetables, fish, white meats, ravioli or other varieties of stuffed pasta, preserving all the vitamins and mineral salts for a richer, fuller and natural flavour



ET50

Geëmailleerde ovenschaal voor 45cm en 60cm ovens. Diepte 50 mm.



GTT2

Volledig uitschuifbare telescopische rails (1 niveau) voor traditionele ovens (SO-)



PALPZ

Pizzapallet inox met plooibaar handvat, 315x325 mm



PR3845X

Inox profiel voor installatie ovens in kolom





SFLK1
Child lock

















STONE2
Rectangular pizza stone without handles, suitable for 45cm and 60cm wide ovens. Dimensions W42 x H1.8 x D37.5cm. Ideal for cooking pizzas with the same results as a typical wood-fired oven. Can also be used for baking bread, focaccias and other recipes such as pies, flans or biscuits

















STONE

Rectangular refractory stone Ideal for cooking pizzas with the same results as a typical wood-fired oven. Can also be used for baking bread, focaccias and other recipes such as pies, flans or biscuits Dimensions:L42 x H1,8 x P37,5 cm.

Symbols glossary

 <p>Sommige modellen zijn voorzien van een functie om het programma/de cyclus te blokkeren zodat het niet per ongeluk kan aangepast worden.</p>	 <p>Defrost by time: Manual defrost function. At the end of the set duration, the function stops.</p>
 <p>Defrost by weight: Automatic defrost function. You choose the type of food to defrost from the available categories (MEAT - FISH - BREAD - DESSERTS). After entering the weight of the food, the oven automatically defines the time required for proper defrosting.</p>	 <p>Ontkalkingsfunctie: Is essentieel om overtollige kalkaanslag in de tank te verwijderen en de goede werking van het product mogelijk te maken. De noodzaak om deze bewerking uit te voeren, wordt door het product zelf aangegeven.</p>
 <p>Quadruple glazed: Number of glazed doors.</p>	 <p>Automatic lighting deactivation: For greater energy savings, the lighting turns off automatically after one minute from the start of cooking. The option can be disabled via the settings menu. In this case the light will remain on for the entire duration of cooking.</p>
 <p>Elektrische aansluiting</p>	 <p>Ever Clean Enamel: Ever Clean enamel is applied electrostatically, corner to corner and edge to edge to prevent cracking or cracks over time. It is a particular pyrolytic enamel, resistant to acids which, in addition to being pleasantly bright, promotes greater cleaning of the oven walls, thanks to its lower porosity. It is baked at over 850 °C and slowly polymerized at a scientifically determined rate to ensure uniform depth and strength. Ever Clean enamel creates an impeccable finish both on the inside of the oven and on the trays, making the surfaces of the oven incredibly easy to maintain over time as it reduces the adhesion of fat during cooking.</p>
 <p>Fresh Touch: Most of Smeg ovens have a "cool door." Thanks to the combination of tangential cooling and internal heat-reflecting glasses, the temperature on the outer surface of the door is maintained below 50° C. In addition to providing safety, this system protects the sides of the furniture from overheating by the oven.</p>	 <p>Ventilator met bovenste en onderste elementen: De elementen in combinatie met de ventilator zijn bedoeld om een meer gelijkmatige warmte te bieden, een methode die vergelijkbaar is met conventioneel koken, dus voorverwarmen is vereist. Het meest geschikt voor items die langzaam koken vereisen.</p>
 <p>Alleen boven- en onder element: een traditionele kookmethode die het meest geschikt is voor losse items in het midden van de oven. de bovenkant van de oven zal altijd het heetst zijn. Ideaal voor gebraden vlees, fruitcake, brood etc.</p>	 <p>Base: the heat comes only from the bottom of the cavity. The fan is not active. Ideal for sweet and savory pies, cobblers and pizzas. Designed to complete cooking and make food more crunchy. This symbol in gas ovens indicates the gas burner.</p>
 <p>Circulaire met onderste element: De toevoeging van het onderste element voegt extra warmte toe aan de basis voor voedsel dat extra moet worden gekookt.</p>	 <p>Circulaire: De combinatie van de ventilator en het ronde element eromheen zorgt voor een hete lucht kookmethode. Dit biedt vele voordelen, waaronder geen voorverwarmen als de kooktijd meer dan 20 minuten bedraagt, geen smaakoverdracht bij het gelijktijdig bereiden van verschillende soorten voedsel, minder energie en kortere kooktijden. Geschikt voor alle soorten voedsel.</p>

-  De combinatie van de grill, de ventilator en onderwarmte is interessant voor het bereiden van kleine hoeveelheden.
-  Fan grill: very intense heat coming only from above from a double heating element. The fan is active. It allows the optimal grilling of thickest meats. Ideal for large cuts of meat.
-  Cooking with the simultaneous use of the heating element in combination with fan and microwave supply.
-  Fan combined with traditional cooking, where heat is generated from above and below, provides uniform heat. Adding the microwave function allows the same cooking results in less time.
-  Met deze functie kunnen sous-vide vacuüm verpakte ingrediënten bereid worden aan de hand van stoom.
-  Een combinatie tussen een turbine en traditioneel bakken, waarbij de warmte boven- en onderin wordt gegenereerd en samen zorgt voor een gelijkmatige warmte. Door toevoeging van stoomfunctie is hetzelfde kookresultaat mogelijk in minder tijd. Ideaal voor gebraden vlees.
-  Dit pictogram/signaal geeft aan dat u water uit de reservoir moet bijvullen of ledigen.
-  Grill: Very intense heat coming only from above from a double heating element. The fan is not active. Provides excellent grilling and gratinating results. Used at the end of cooking, it gives a uniform browning to dishes.
-  Microwave: Penetrating straight into the food, microwaves cook very quickly and with considerable energy savings. Suitable for cooking without fat, they are also able to thaw and heat food without altering its original appearance and aroma. The microwave function can also be combined with conventional functions with all the resulting advantages. Ideal for all types of food.
-  Microwave + grill element: The use of the grill results in a perfect browning of the surface of the food. The action of microwaves allows instead of cooking in a short time the internal part of the food.
-  Pizza function: Specific function for cooking pizza in a pan. It allows to obtain a pizza that is soft inside and crispy outside with the topping perfectly cooked, not dry and not burnt.
-  Koken met stoom: het is een natuurlijke manier van koken voor alle soorten producten, van groenten tot desserts, om de nutritionele en organoleptische eigenschappen van ingrediënten te behouden. Ideaal om te koken zonder vet, om voedsel op te warmen zonder uit te drogen. Stoom is ideaal voor het gelijktijdig bereiden van maaltijden die verschillende kooktijden vereisen.
-  Circulaire-element met stoom: koken met gelijktijdig gebruik van het ronde verwarmingselement in combinatie met ventilator en stoomtoevoer.
-  Circulaire met bovenste en onderste elementen: door het gebruik van de ventilator met beide elementen kan voedsel snel en effectief worden gekookt, ideaal voor grote stukken vlees die grondig moeten worden gekookt. Het biedt een vergelijkbaar resultaat als rotisserie, waarbij de warmte rond het voedsel wordt verplaatst in plaats van het voedsel zelf te verplaatsen, waardoor elke maat of vorm kan worden gekookt.

- 

Voor het creëren van een perfect geroosterd vleesgewricht. Het extra vocht houdt het vlees sappig en mals, terwijl de warmte van de grill zorgt voor een krokante korst.



Circulaire met stoomondersteuning: zorgt voor extra vocht tijdens het koken. Uitstekend geschikt voor het bakken van brood. Door het vocht kan het brooddeeg aan het begin van het koken verder uitrekken, waardoor een luchtig en licht gestructureerd deeg ontstaat. Het resterende deel van het kookproces zorgt ervoor dat de kenmerkende korst zich vormt.
- 

Circulatie + onderelement met stoomondersteuning: ideaal voor het opwarmen van taartjes en quiches. Met deze functie wordt de bodem opnieuw knapperig, terwijl de vulling niet uitdroogt door het extra vocht in de kookruimte.



Circulatie met Steam assist: zorgt voor extra vocht tijdens het koken. Uitstekend geschikt voor het bakken van brood. Door het vocht kan het brooddeeg aan het begin van het koken verder uitrekken, waardoor een luchtig en licht gestructureerd deeg ontstaat. Het resterende deel van het kookproces zorgt ervoor dat de kenmerkende korst zich vormt.
- 

Voor het creëren van een perfect geroosterd stuk vlees. Het extra vocht houdt het vlees sappig en mals, terwijl de warmte van de turbofunctie zorgt voor de gekarameliseerde smaken die we kennen en waar we van houden.



All glass inner door: All glass inner door, a single flat surface which is simple to keep clean.
- 

Met deze functie kan u bereidingen warmhouden zodat het eten niet meteen afkoelt







Plate rack warming: function for heating or keeping dishes warm. Place the baking tray on the lowest shelf and stack the dishes to be heated.
- 

Koken met temperatuursonde: het is mogelijk om de temperatuur die herkend is door de sonde weer te geven op het display en een doeltemperatuur voor het gerecht in te stellen. Wanneer het centrum van het gerecht de juiste temperatuur heeft bereikt, stopt de functie.



Air at 40°C provides the perfect environment for proving yeast type dough mixes. Simply select the function and place dough in the cavity for allotted
- 

Rapid preheating: cooking is preceded by the preheating phase which allows the cooking compartment to reach the set temperature. This option reduces the time by up to 50%.



SABBATH: function that allows to cook food respecting Judaism's day of rest provisions.
- 

Option designed to solve any doubts More than 100 pop-ups, which can be triggered with a long touch on any icon, provide information on the use of the display and cooking.



The oven cavity has 5 different cooking levels.
- 

Smart Cooking is the perfect recipe for every occasion. Meat, fish, pasta, desserts, etc . up to 150 automatic recipes that allow to make any preparation in a single click. Decide your menu and then the oven takes care of the rest.

















Appliances with Wi-Fi connectivity. Via SmegConnect App is possible to monitor and remotely control appliances through smartphone and tablet (iOS and Android).
- 

Alle modellen zijn voorzien van een soft close deursysteem waarbij de deur zacht en stil sluit.



Multistep Cooking: It is possible to set up to 3 cooking phases during the same recipe. Cooking technology, function, time and temperature can be varied. At the end of a phase, the following will start automatically.

-  To guarantee the optimal functioning of the appliance, it is suggested to carry out the tank cleaning roughly once every 2-3 months.
-  Electronic control: Allows you to maintain temperature inside the oven with the precision 2-3 ° C. This enables to cook meals that are very sensitive to temperature changes, such as cakes, souffles, puddings.
-  The capacity indicates the amount of usable space in the oven cavity in litres.
-  Met deze functie kan je alle types gekookt voedsel warmhouden.
-  Active and controlled microwave distribution. The Microwave Stirrer fan distributes the waves evenly within the oven, reducing the need for a turntable.
-  The latest generation of LED lights, positioned over the entire height of the cavity, guarantee perfect multi-level visibility. No matter how many trays you put in the oven, the food inside will always be clearly visible and you can check the progress of the cooking process. In addition to the guaranteed efficiency, the LED lights also have a modern look and low energy consumption, saving up to 80% of costs and lasting 25 times longer than traditional halogen bulbs.
-  The water load system is designed to enhance the aesthetics of the oven. The loading and unloading tube can be easily removed from the oven and the water refilled at any time during the cooking cycle, without opening the door, guaranteeing an infinite duration of steam.
-  Telescopic rails: allow you to pull out the dish and check it without having to remove it from the oven entirely.
-  Vapor Clean: a simple cleaning function using steam to loosen deposits in the oven cavity.
-  The capacity indicates the amount of usable space in the oven cavity in litres.
-  Breed touch display
-  INSTANT GO: activating this option allow to start cooking immediately. Preheating is included in the cooking time and the oven will gradually reach the desired temperature Particularly suitable for frozen foods.
-  De multipoint temperatuursonde heeft drie detectiepunten. Hierdoor wordt niet alleen de kerntemperatuur gedetecteerd, maar ook de temperatuur in andere delen. De oven verwerkt al deze gegevens om ongelijkmatige bereidingen te voorkomen. Op deze manier kan elk product in een professionele restaurantstijl worden gekookt.
-  Only with Galileo Multi Cooking technology is it possible to combine up to three different technologies and take the best out of them: steam, microwave, convection cooking. Ovens of this generation can use any of these cooking methods individually or can combine them as desired. Both following a horizontal cooking approach (multistep) in which the various cooking techniques are arranged in sequence, and a vertical approach (multitech) in which there is a totally free combination of the three of them at the same time. Steam is healthy, microwaves are fast and traditional cooking is crispy. The oven knows how to dose them and use them wisely to guarantee innovative results with a time saving up to 70% comparing to traditional cooking.
-  De perfecte manier om in een paar simpele stappen een compleet menu te hebben met een flinke tijds winst. De grote ovenruimte biedt plaats aan meerdere soorten voedsel tegelijk, die kunnen worden gekookt zonder geurwisseling. De zorgvuldig bestudeerde thermodynamische stromen zorgen voor uniform koken op elk niveau. Het SameTime-algoritme berekent de tijden, de kookfuncties en alle parameters zodat 3 gerechten tegelijk klaar kunnen zijn



The inverter technology allows to generate microwaves continuously and at the desired power. The constant flow, without on and off cycles, allows you to precisely control the temperature, reduce times, avoids wasting energy and allows you to obtain excellent cooking, defrosting and re-heating results, thanks to the smaller difference between core and surface temperature in food.



Speciale kookfunctie voor het Airfryerrek AIRFRY. Ideaal voor het nabootsen van traditioneel frituren in de oven, maar met minder calorieën en minder vet. Hiermee kook je snel en eenvoudig gerechten zoals frites, gebakken groenten en vis, waardoor ze perfect bruin en krokant worden.



The double chimney technology create a special airflow inside the cavity that reduce the condensation inside the cavity during microwave cooking, where the cavity is cold and the food is warm



Function to melt butter and chocolate without using the bain-marie



Function for the preparation of popcorn packaged in bags



Speciale kookfunctie voor de dubbelzijdige plaat-BBQ. Geschikt voor het nabootsen van sappige en knapperige gerechten in de oven met de typische smaak van gegrild koken. De geribbelde kant is bijzonder geschikt voor vleeswaren en kazen; de gladde kant voor vis, zeevruchten en groenten.



Speciale kookfunctie voor de pizzasteen STONE. Ideaal voor het bakken van pizza's met hetzelfde resultaat als een typische houtgestookte oven. Kan ook worden gebruikt voor het bakken van brood, focaccia's en andere recepten zoals taarten, vlaaien of koekjes



DeltaT cooking The oven automatically sets the cavity temperature to a predefined temperature (named deltaT) higher than the core temperature detected by the probe. When the probe detects an extra degree at the core, the oven automatically increases also its internal temperature by one degree. The oven offers the possibility to choose between three different deltaT cooking modes (slow, medium and fast) and to set any desired core temperature. A concentration of technology that makes it possible to obtain tender, juicy, healthy products of the highest quality.



Function to soften butter and cheese It is useful for quickly bringing frozen desserts to serving temperature The function can also be used to soften ice cream