

SPF516S

Família	Máquina de lavar louça profissional
Subfamília	Raised
Tipo	Raised traywasher
Louça	Louça; Talheres; EN 600x400 trays; GN1/1 trays
Dimensões do cesto	500x500 mm
Painel de comandos	Controlo eletrónico da temperatura
Standard drain pump with partial water renewal in the wash tank	Sim
Bomba de enxaguamento	HTR system
Tipo de caldeira	Atmosferic boiler
Bomba de lavagem	Standard
Ligação energética	400 V 3N~ / 12 A / 7,3 kW / 50 Hz
Dimensões do produto (LxPxA)	600x690x1315 mm



Mercado

Indústrias	Hotelaria; Restaurantes / Catering; Padarias / Pastelarias; Estabelecimentos de Cuidados; Catering; Indústrias Alimentares; Talhós
-------------------	------------------------------------------------------------------------------------------------------------------------------------------------------

Design

Cor dos LEDs	Verde	Design	Easyline
---------------------	-------	---------------	----------

Especificações técnicas

Trays number	7 x GN1/1; 6 x EN 600x400	Dureza máxima da água	60°f - 34°dH
Opção de lavagem dos tabuleiros	Sim	Pressão de entrada	100-1000 kPa (min-max)
Consumo de água por ciclo	3,2 l	Carga de detergente	1,5 l/h
Temperatura de enxaguamento a frio	No	Carga de enxaguamento	0,4 l/h
Temperatura pré-definida de ligação da água	5°C	Altura de carga operável	400 mm
Consumo mínimo de água por ciclo	3,2 l	Profundidade com porta aberta	1290 mm
Temperatura máxima de entrada:	60°C	Diâmetro máximo dos pratos	415 mm

Programas

Programas	6 programas automáticos; 1 fully customizable program; Programas de autolimpeza
Opções do programa	Enxaguamento extra; Ciclo da água limpa
Tabela de programas	Easyline dishwasher and traywasher 500
Numero máximo de cestos/hora	51
Numero máximo de pratos/hora	720
Numero máximo de copos/hora	2160

Ligação eléctrica

Potência do elemento de aquecimento do tanque	2000 W	Ligação pré-definida	7300 W
Potência do elemento de aquecimento da caldeira	6100 W	Ligação eléctrica opcional	220 V 3~ / 19 A / 6,8 kW / 60 Hz; 220 V 3~ / 19 A / 7,3 kW / 60 Hz; 230 V~ / 15 A / 3,4 kW / 50 Hz; 230 V~ / 17 A / 3,9 kW / 50 Hz; 230 V~ / 20 A / 4,5 kW / 50 Hz; 230 V~ / 22 A / 5,0 kW / 50 Hz; 400 V 3N~ / 12 A / 6,8 kW / 50 Hz
Potência da bomba de lavagem	700 W	Ficha eléctrica	Não

Interface

Display	8 dígitos	Alerta de falta de detergente	Sim
Luz indicadora On/Off	Sim	Indicador da fase do programa	Sim
Luz indicadora de falta de sal	Sim	Indicador de fim do programa	Sim
Alerta de falta de abrillantador	Sim	Diagnóstico manual	Sim

ESPECIFICAÇÕES TÉCNICAS

Cuba	Profundo	Guias dos cestos	Embutidas
Tipologia	Parede dupla	Filtro	Sistema de filtragem de 5 estágios
Material da cuba	Aço inox AISI 304	Capacidade da cuba	11 l
Painel traseiro	St/steel	Capacidade da caldeira	6,5 l
Porta equilibrada	Sim	Ruído	Lpa 54,5 dBA
Sistema de lavagem superior	Um braço de lavagem e um braço de enxaguamento dividido, em aço inoxidável.	Classe de Protecção	IPX4
Sistema de lavagem inferior	One wash and one split rinse spray arms, stainless steel	Pés ajustáveis	Sim
Filtro da cuba	Aço inox	Altura max. de drenagem	600 mm
Junta da porta	Em 3 lados		

Acessórios incluídos

Cesto para talheres	1x PHOOS04	Mangueira de abastecimento de água	Sim - 2m
Cesto de fundo plano	1x PB50G02	Mangueira de drenagem	Sim - 2m
Grelhas	1 x KIT-WG500		

Equipamentos

Dispensador peristáltico de detergente	Controlo eletrónico	Opção para ativação automática diária	Sim, desligado por definição
Dispensador peristáltico de abrilhantador	Controlo eletrónico	Contador de ciclos	Sim
Sonda de nível químico	Sim, opcional KITSONLIV	Tanque de Ruptura	Sim
Amaciador automático incorporado	Sim	Diâmetro do tudo de abastecimento de água	DN15 - ½"
Sistema Thermostop para caldeira de enxaguamento	Yes - default	Ø do tubo de drenagem	DN20-G 3/4"
Sistema Thermostop no tanque de lavagem	Sim	Comprimento da mangueira de detergente (vermelha)	2,2 m
Sistema de arranque suave da bomba de lavagem	Sim	Comprimento da mangueira de enxaguamento (azul)	2,2 m
Sistema Stand-by	Sim		

Dados de logística

Código EAN	8017709345747	Peso líquido (kg)	91,000 kg
Dimensões do produto embalado (LxPxA)	660x700x1470 mm	Peso bruto (kg)	101,000 kg

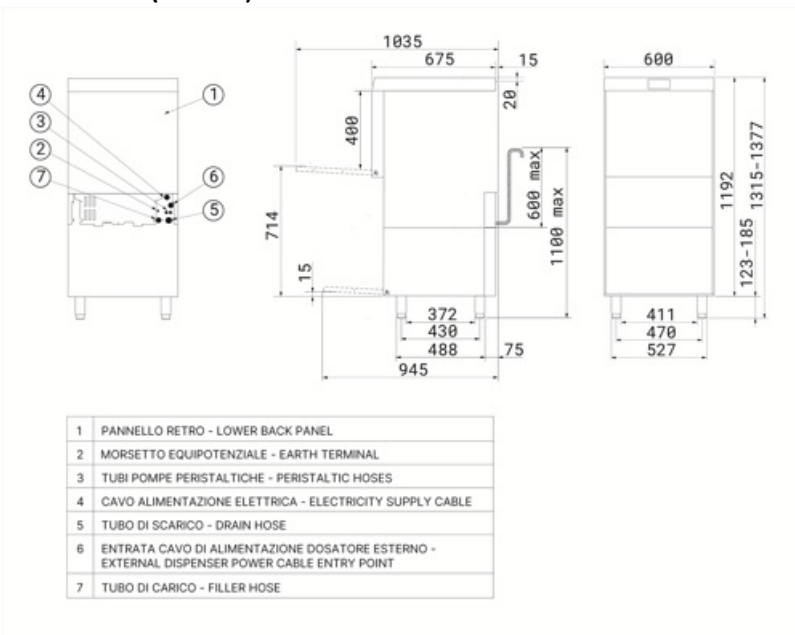

Acessórios Compatíveis

KITSONLIV

Probe level kit



PB50D01

Polypropylene basket for 18 plates
Ø250 mm max, dim.(WxDxH)
500x500x105 mm

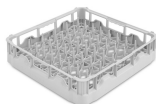

PB50T01

Polypropylene basket for 8 trays GN 1/1
h 40 mm for traywasher and hood-type
models. Vertical row spacing 68 mm and
horizontal row spacing 54 mm, dim.
(WxDxH) 500x500x105 mm

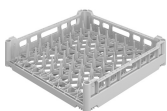

PHOOS04

4 compartments polypropylene basket
for cutlery



WB50T02

Wire basket for 7 trays GN1/1 h 20 mm,
dim. (WxD) 500x500 mm



WH00S01

Wire insert for 17 small dishes, width
100 mm, for flat bottom baskets
500x500 and 600x500 mm

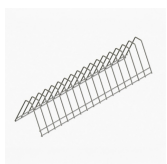

KIT-WG500

Support grid for tray washer, dim.
(WxD) 500x500 mm

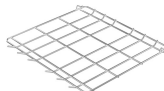

PB50G02

Universal flat bottom polypropylene
basket, internal height 150 mm, dim.
(WxDxH) 500x500x170 mm

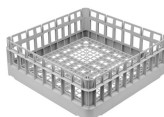

PHOOS01

Polypropylene single basket for
cutlery



WB50D01

Wire basket for 18 dishes Ø250 mm
max or trays h 370 mm, dim. (WxDxH)
500x500x92 mm



WB50T03

Wire basket for 6 trays GN1/1 h 60
mm and EN 600x400 mm for double-
skin model. 64 mm row spacing, dim.
(WxDxH) 500x500x206 mm



Benefit (TT)

Balanced door

Effortless opening and closing

The counterbalanced door is designed to ensure smooth and effortless opening and closing, providing high user convenience. Additionally, it can be locked in a halfway position, a particularly useful feature for promoting natural drying at the end of the workday, enhancing overall hygiene and preventing the buildup of residual moisture.

5-stage system

Deep cleaning and spotless washes with the patented filtration system

The innovative Smeg filtration system consists of 5 stages to completely eliminate all impurities: the 1st stage captures larger food residues; in the 2nd and 3rd stages, finer particles are captured at this filtration stage; the 4th stage features a pre-filtration grid to prevent debris from entering the tank and clouding the water. Finally, the last stage is designed to further protect the washing and draining pumps from any debris that may accidentally enter the tank during filter cleaning.

HTR System

Consistent temperatures and pressures for uniform and effective dishwashing

Thanks to the HTR system (High Temperature Rinse) and the presence of the atmospheric boiler combined with the Thermostop, the cold inlet water does not enter the boiler during rinsing, ensuring a constant rinsing temperature according to the program setting. The HTR system keeps the water hot for deep sanitisation and quick drying, ensuring constant pressure for uniform and effective cleaning.

Moulded tank

Superior washing performance and enhanced cleaning convenience with molded tub bottoms and basket guides

Smeg dishwashers are designed with moulded tank and basket guides. The absence of sharp edges ensures an optimised wash flow, guaranteeing hygiene and impeccable cleaning performance. Furthermore, this innovative design simplifies machine cleaning, reducing the need for maintenance interventions.

Integrated softener

Effective water treatment for consistently sparkling glasses

The integrated continuous regeneration water softener ensures effective water treatment, enhancing washing performance and preserving the machine's operational lifespan. The resin regeneration process takes place during the wash cycle without interruptions, providing constant control over water hardness. This system prevents limescale buildup, maximises detergent efficiency, and guarantees spotless results on glassware and dishes.

Integral double-skin

Thermal and acoustic insulation guaranteed

The double-skin design of undercounter dishwashers is engineered to optimise energy efficiency by minimising heat loss and accelerating water heating, resulting in lower energy consumption and faster start-up times. Additionally, it provides effective sound insulation, helping to reduce noise levels and ensuring a quieter, more comfortable working environment for staff.

Drain pump

Partial water replacement during the wash cycle for clean and hygienic dishes

The standard drain pump, equipped with a partial water exchange system, ensures that the dirtiest water is automatically removed at every wash cycle. This mechanism allows for continuous renewal of the water used, ensuring that each phase of the washing process is carried out with clean water. The result is optimal dishwashing performance, with outstanding efficiency and an impeccable level of hygiene.

Soft-start system

Effective management of the washing pump to protect your glassware

The Soft-Start function initiates the wash cycle gently and gradually, progressively increasing the water pressure. This system has been designed to provide optimal protection for the most fragile items, such as crystal glasses, significantly reducing the risk of chipping or damage. At the same time, it ensures excellent cleaning performance, combining efficiency and safety in every wash cycle.

Raised version

Easy and fast dishwasher loading and unloading operations

The raised design facilitates loading and unloading dishes, making these tasks faster and more efficient. This results in significant time savings, especially valuable in high-intensity work environments. The space below the dishwasher can be used to store detergents, utensils, or other accessories, providing a practical solution to optimise space usage, particularly in compact kitchens.

Euronorm

Compatibility with EN 600x400 mm trays

These models offer great versatility, with the ability to wash up to 6 Euronorm 600x400 mm trays. These features make the products extremely useful for a wide range of activities, such as pizzerias, bakeries, bistros, catering, restaurants, and cafés.