

SPH615H

Família	Máquina de lavar louça profissional
Subfamília	Máquina de lavar louça de capota
Tipo	Máquina de lavar louça de capota
Louça	Louça; Copos; Talheres; EN 600x400 trays; GN1/1 trays
Dimensões do cesto	600x500 and 500x500 mm
Painel de comandos	Controlo eletrónico da temperatura
Standard drain pump with partial water renewal in the wash tank	Sim
Bomba de enxaguamento	HTR system
Tipo de caldeira	Atmosferic boiler
Bomba de lavagem	Standard
Sistema SHR	Sim
Ligação energética	400 V 3N~ / 16 A / 9,7 kW / 50 Hz
Dimensões do produto (LxPxX)	734x750x1523 mm



Mercado

Indústrias	Hotelaria; Restaurantes / Catering; Padarias / Pastelarias; Indústrias Alimentares; Estabelecimentos de Cuidados; Supermercados / Comércio de alimentos; Catering; Indústrias Alimentares; Talhos
------------	---

Design

Cor dos LEDs	Verde	Design	Easyline
--------------	-------	--------	----------

Especificações técnicas

Trays number	7 x GN1/1; 6 x EN 600x400	Temperatura máxima de entrada:	20°C
Opção de lavagem dos tabuleiros	Sim	Dureza máxima da água	5°f - 3°dH
Consumo de água por ciclo	3,2 l	Pressão de entrada	100-1000 kPa (min-max)
Temperatura de lavagem (mín.-máx)	58 °C	Carga de detergente	1,5 l/h
Temperatura de enxaguamento (mín.-máx.)	71 °C - 87 °C	Carga de enxaguamento	0,4 l/h
Temperatura de enxaguamento a frio	No	Altura de carga operável	470 mm
		Altura máxima com a capota aberta	2138 mm

Temperatura pré-definida de ligação da água	5°C
Consumo mínimo de água por ciclo	3,2 l

Programas

Programas	6 programas automáticos; 1 fully customizable program; Programas de autolimpeza
Opções do programa	Enxaguamento extra; Ciclo da água limpa
Tabela de programas	Easyline hoodtype
Numero máximo de cestos/hora	60
Numero máximo de pratos/hora	1320
Numero máximo de copos/hora	3360

Ligação eléctrica

Potência do elemento de aquecimento do tanque	2200 W	Ligação pré-definida	9700 W
Potência do elemento de aquecimento da caldeira	9000 W	Ligação eléctrica opcional	230 V~ / 16 A / 3,7 kW / 50 Hz; 230V~ / 26 A / 9,7 kW / 50 Hz ; 230 V~ / 30 A / 6,7 kW / 50 Hz
Potência da bomba de lavagem	700 W	Ficha eléctrica	Não

Interface

Display	8 dígitos	Indicador da fase do programa	Sim
Luz indicadora On/Off	Sim	Indicador de fim do programa	Sim
Alerta de falta de abrillantador	Sim	Diagnóstico manual	Sim
Alerta de falta de detergente	Sim		

ESPECIFICAÇÕES TÉCNICAS

Cuba	Profundo	Filtro	Sistema de filtragem de 5 estágios
Tipologia	Double-skin hood	Capacidade da cuba	22 l
Material da cuba	Aço inox AISI 304	Capacidade da caldeira	10 l
Painel traseiro	Previamente pintado	Ruído	Lpa 59,9 dBA
Sistema de lavagem superior	Um braço de lavagem e um braço de enxaguamento dividido, em aço inoxidável.	Classe de Protecção	IPX4
Sistema de lavagem inferior	One wash and one split rinse spray arms, stainless steel	Pés ajustáveis	Sim
Filtro da cuba	Aço inox	Altura max. de drenagem	1000 mm
Hood elevation system	Manual		

Acessórios incluídos

Cesto para pratos	1x PB60D01	Mangueira de abastecimento de água	Sim - 2m
Cesto para talheres	1x PHOOS03	Mangueira de drenagem	Sim - 2m
Cesto de fundo plano	1x PB60G01		

Equipamentos

Dispensador peristáltico de detergente	Controlo eletrónico	Opção para ativação automática diária	Sim, desligado por definição
Dispensador peristáltico de abrilhantador	Controlo eletrónico	Contador de ciclos	Sim
Sonda de nível químico	Sim, opcional KITSONLIV	Tanque de Ruptura	Sim
Unidade de medida da dosagem de produtos químicos	gr/lt	Diâmetro do tudo de abastecimento de água	DN15 - ½"
Sistema Thermostop para caldeira de enxaguamento	Yes - default	Ø do tubo de drenagem	DN20-G 3/4"
Sistema Thermostop no tanque de lavagem	Sim	Comprimento da mangueira de detergente (vermelha)	2,2 m
Sistema de arranque suave da bomba de lavagem	Sim	Comprimento da mangueira de enxaguamento (azul)	2,2 m
Sistema Stand-by	Sim		

Dados de logística

Código EAN	8017709342920	Peso líquido (kg)	146,000 kg
Dimensões do produto embalado (LxPxA)	770x900x1700 mm	Peso bruto (kg)	162,000 kg

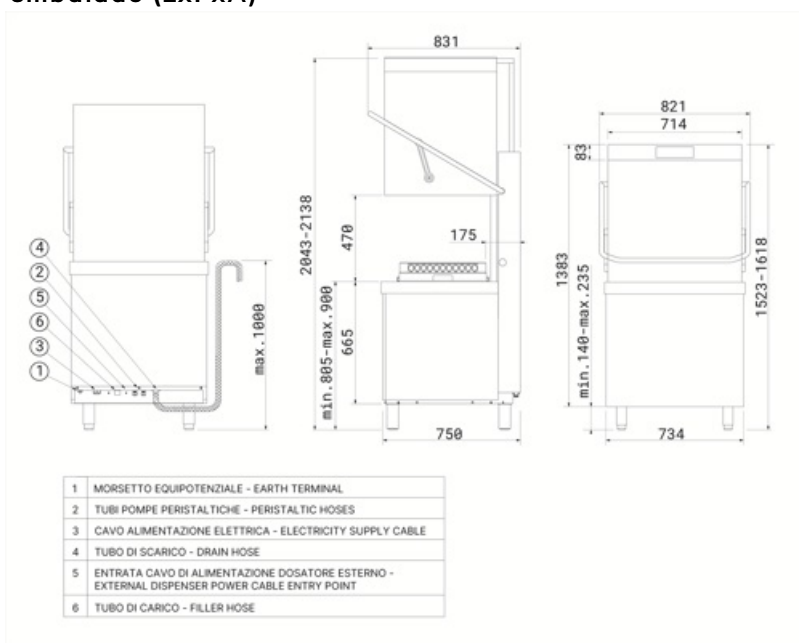

Acessórios Compatíveis



KITSONLIV

Probe level kit



PB50G01

Universal flat bottom polypropylene basket, internal height 73 mm, dim. (WxDxH) 500x500x100 mm

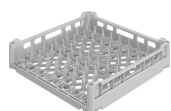

PB50T01

Polypropylene basket for 8 trays GN 1/1 h 40 mm for traywasher and hood-type models. Vertical row spacing 68 mm and horizontal row spacing 54 mm, dim. (WxDxH) 500x500x105 mm



PB60G01

Universal flat bottom polypropylene basket, dim. (WxDxH) 600x500x115 mm



PHOGR5

Tilted glass insert for basket PB50G02 500x500 mm, configurable with 4 units of 5 glasses each (first line Ø max 110 mm, lines 2-4 Ø max 95 mm), or 5 units of 5 glasses each (first line Ø max 95 mm, lines 2-5 Ø max 75 mm)



PHOOS03

8 compartments polypropylene basket for cutlery

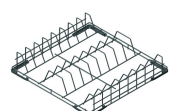

WB50D01

Wire basket for 18 dishes Ø250 mm max or trays h 370 mm, dim. (WxDxH) 500x500x92 mm



WB50G02

Wire basket with sloped bottom for 25 glasses Ø90 mm max, dim. (WxDxH) 500x500x170 mm

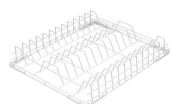

WB60D01

Wire basket for 24 dishes Ø260 mm max, dim. (WxD) 600x500 mm

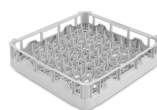

PB50D01

Polypropylene basket for 18 plates Ø250 mm max, dim.(WxDxH) 500x500x105 mm

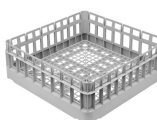

PB50G02

Universal flat bottom polypropylene basket, internal height 150 mm, dim. (WxDxH) 500x500x170 mm



PB60D01

Polypropylene basket for 22 dishes Ø290 mm max, dim. (WxDxH) 600x500x115 mm



PB60T02

Basket for 10 GN 1/1 trays or 12 trays up to 470 mm in length, row spacing 45 mm, dimensions (WxDxH) 600x500x100 mm



PHOOS01

Polypropylene single basket for cutlery



PHOOS04

4 compartments polypropylene basket for cutlery



WB50G01

Universal wire basket with flat bottom, internal height 120 mm, dim. (WxDxH) 500x500x130 mm



WB50G04

Wire basket with sloped bottom for 12 glasses Ø110 mm max or 9 glasses Ø135 mm max, dim. (WxDxH) 500x500x165 mm



WB60D02

Wire basket for 16 pizza dishes Ø320 mm max

WB60G01



Wire basket with flat bottom, internal height 110 mm, dim. (WxDxH) 600x500x120 mm

WH00S01



Wire insert for 17 small dishes, width 100 mm, for flat bottom baskets 500x500 and 600x500 mm

WT51200SHR



Entry table right side with sink and scraping hole, splashback (100mm) and lower shelf, dim. (WxDxH) 1200x720x821,5 mm

WB60T03

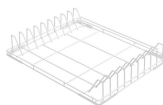

Wire basket for 9 trays EN 600x400 mm, dim. (WxD) 600x500 mm

WT51200SHL



Entry table left side with sink and scraping hole, splashback (100mm) and lower shelf, dim. (WxDxH) 1200x720x821,5 mm

WT51200SL



Entry table left side with sink, splashback (100mm) and lower shelf, dim. (WxDxH) 1200x720x821,5 mm

WT51200SR



Entry table right side with sink, splashback (100mm) and lower shelf, dim. (WxDxH) 1200x720x821,5 mm

WT5700SR



Entry table right side with sink, splashback (100mm) and lower shelf, dim. (WxDxH) 700x720x821,5 mm

WTC5L



Left side closure kit for Hoodtype

WTC5R



Right side closure kit for Hoodtype

WTX51200



Universal entry/exit table for either side, with lower shelf, dim. (WxDxH) 1200x560x821,5 mm

WTX51200L



Exit left side table, with splashback (100 mm) and lower shelf, dim. (WxDxH) 1200x720x821,5 mm

WTX51200R



Exit right side table, with splashback (100 mm) and lower shelf, dim. (WxDxH) 1200x720x821,5 mm

WTX5700



Universal entry/exit table for either side, with lower shelf. dim. (WxDxH) 700x560x821,5 mm

WTX5700L



Exit table left side, with back splashback (100mm) and lower shelf, dim. (WxDxH) 700x720x821,5 mm

WTX5700R



Exit table right side, with back splashback (100mm) and lower shelf, dim. (WxDxH) 700x720x821,5 mm



WTX6700F

Universal table for either side, with front coupling and lower shelf, dim. (WxDxH)
705x660x821,5 mm

Benefit (TT)

5-stage system

Deep cleaning and spotless washes with the patented filtration system

The innovative Smeg filtration system consists of 5 stages to completely eliminate all impurities: the 1st stage captures larger food residues; in the 2nd and 3rd stages, finer particles are captured at this filtration stage; the 4th stage features a pre-filtration grid to prevent debris from entering the tank and clouding the water. Finally, the last stage is designed to further protect the washing and draining pumps from any debris that may accidentally enter the tank during filter cleaning.

HTR System

Consistent temperatures and pressures for uniform and effective dishwashing

Thanks to the HTR system (High Temperature Rinse) and the presence of the atmospheric boiler combined with the Thermostop, the cold inlet water does not enter the boiler during rinsing, ensuring a constant rinsing temperature according to the program setting. The HTR system keeps the water hot for deep sanitisation and quick drying, ensuring constant pressure for uniform and effective cleaning.

SHR+ System

Steam heat recovery system for energy savings and improved work environment quality

The SHR+ system eliminates the steam produced during the rinsing phase, improving air quality and reducing humidity in work environments. In addition, it recovers energy from the condensed vapors, ensuring daily energy savings and avoiding the costs of an external extraction system.

Moulded tank

Superior washing performance and enhanced cleaning convenience with molded tub bottoms and basket guides

Smeg dishwashers are designed with moulded tank and basket guides. The absence of sharp edges ensures an optimised wash flow, guaranteeing hygiene and impeccable cleaning performance. Furthermore, this innovative design simplifies machine cleaning, reducing the need for maintenance interventions.

Double-skin hood

Thermal and acoustic insulation guaranteed

The double-skin design of the hood is engineered to optimise energy efficiency by minimising heat dispersion and accelerating water heating, resulting in lower energy consumption and faster start-up times. Additionally, it provides effective sound insulation, helping to reduce noise levels and ensuring a quieter, more comfortable working environment for staff.

Drain pump

Partial water replacement during the wash cycle for clean and hygienic dishes

The standard drain pump, equipped with a partial water exchange system, ensures that the dirtiest water is automatically removed at every wash cycle. This mechanism allows for continuous renewal of the water used, ensuring that each phase of the washing process is carried out with clean water. The result is optimal dishwashing performance, with outstanding efficiency and an impeccable level of hygiene.

Soft-start system

Effective management of the washing pump to protect your glassware

The Soft-Start function initiates the wash cycle gently and gradually, progressively increasing the water pressure. This system has been designed to provide optimal protection for the most fragile items, such as crystal glasses, significantly reducing the risk of chipping or damage. At the same time, it ensures excellent cleaning performance, combining efficiency and safety in every wash cycle.

Hood lift

Unprecedented comfort with the patented lifting system

The new ergonomic handle, combined with the patented lifting system, minimises the effort required to open and close the hood, limiting it to just 2.5 kg. This system ensures an exceptionally smooth and lightweight operation, helping to protect the operator's health and well-being, even during extended use.

Euronorm

Compatibility with EN 600x400 mm trays

These models offer great versatility, with the ability to wash up to 6 Euronorm 600x400 mm trays. These features make the products extremely useful for a wide range of activities, such as pizzerias, bakeries, bistros, catering, restaurants, and cafés.