

SUK92MX9-1

Categorie fornuis	90x60 cm
Aantal ovens met energielabel	2
Cavity heat source	Elektrisch
Type kookplaat	Gas
Type primaire oven	Thermogeventileerd
Type secundaire oven	Statisch
Reinigingssysteem primaire oven	Vapor Clean
EAN-code	8017709282639
Energie-efficiëntieklasse	A
Energie-efficiëntieklasse, tweede oven	A



Design



Esthetiek	Classici	Bedieningsknoppen	Smeg Classici
Series	Concerto	Kleur knoppen	Roestvrij staal
Design	Standaard	Aantal bedieningsknoppen	8
Kleur	Roestvrij staal	Kleur serigrafie	Zwart
Afwerking	Geborsteld	Display	Elektronisch 5 toetsen
Afwerking bedieningspaneel	Roestvrij staal	Deur	Met 2 horizontale stroken
Logo	In reliëf	Type glas	Stopsol
Positie logo	Strook onder de oven	Handgreep	Smeg Classici
Upstand	Ja	Kleur handgreep	Geborsteld roestvrijstaal
Kleur kookplaat	Roestvrij staal	Opbergruimte	Klep
Type pannendragers	Gietijzer	Pootjes	Zilver
Type bediening	Bedieningsknoppen	Plint	Zwart

Programma's / functies

Aantal kookfuncties 6

Traditionele kookfuncties

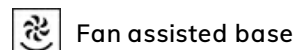
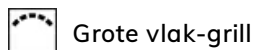

Schoonmaak functie



Programma's / functies secundaire oven

Kookfuncties ovenruimte 2

4

Traditionele kookfuncties, ovenruimte 2



Statisch



Kleine grill

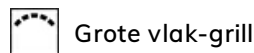

Grote vlak-grill

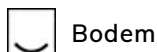

Bodem

Technische specificaties kookplaat

UR

Totaal aantal kookzones 5

Linksvoor - Gas - RP - 3.00 kW

Linksachter - Gas - SRD - 1.80 kW

Midden - Gas - URP - 3.50 kW

Rechtsachter - Gas - SRD - 1.80 kW

Rechtsvoor - Gas - AUX - 1.00 kW

Type gasbranders Standaard

Thermobeveiliging

Ja

Automatische
vonkontsteking

Ja

Branderdeksels

Mat zwart geëmailleerd

Technische specificaties primaire oven



Aantal lampen 1

Aantal ventilatoren 1

Netto inhoud 70 l

Bruto inhoud 1e oven 79 l

Materiaal ovenruimte Ever Clean emaille

Aantal kookniveaus 5

Type ovenrekken Metalen zijsteunen

Soort verlichting Halogeen

Vermogen lamp 40 W

Instelling kooktijd Start en stop

Automatische

inschakeling verlichting
bij openen deur

Ja

Uitneembare ovendeur Ja

Volledig glazen

binnendeur

Ja

Uitneembaar glas
binnendeur

Ja

Aantal ruiten ovendeur 3

Aantal thermo-

reflecterende ruiten 1

Veiligheidsthermostaat Ja

Koelsysteem Mantelkoeling

Afmetingen bruikbare

interne ovenruimte
(hxbxd)

360X460X425 mm

Temperatuurregeling Elektro-mechanisch

Onderwarmte -

vermogen

1200 W

Bovenwarmte -

vermogen

1000 W

Grill - vermogen

1700 W

Circulatie - vermogen

2000 W

Type grill Elektrisch

Kantelbare grill Ja

Opties primaire oven

Timer	Ja	Minimum temperatuur	50 °C
Akoestisch signaal einde kooktijd	Ja	Maximum temperatuur	260 °C

Technische specificaties secundaire oven



Netto inhoud (l) oven 2	35 l	Aantal ruiten ovendeur	3
Bruto inhoud, 2e oven	36 l	Aantal thermo-reflecterende ruiten	1
Materiaal ovenruimte	Ever Clean emaille	Veiligheidsthermostaat	Ja
Aantal kookniveaus	4	Koelsysteem	Mantelkoeling
Type ovenrekken	Metalen zijsteunen	Afmetingen bruikbare interne ovenruimte (hxbxd)	311x206x418 mm
Aantal lampen	1	Temperatuurregeling	Elektro-mechanisch
Soort verlichting	Gloeilamp	Onderwarmte - vermogen	700 W
Vermogen lamp	25 W	Bovenwarmte - vermogen	600 W
Uitneembare ovendeur	Ja	Grill - vermogen	1300 W
Volledig glazen binnendeur	Ja	Grote vlakgrill - vermogen	1900 W
Uitneembaar glas binnendeur	Ja	Type grill	Elektrisch

Opties secundaire oven

Minimum temperatuur	50 °C	Maximum temperatuur	245 °C
---------------------	-------	---------------------	--------

Meegeleverde accessoires primaire oven en kookplaat



Houder t.b.v. caffettiera	1	Inzetrooster	1
Rek met achter- en zijstop	2	Telescopische geleiders, gedeeltelijk uitschuifbaar	1
Bakplaat (40 mm)	1		

Meegeleverde accessoires secundaire oven

Rek met achter- en zijstop	1	Inzetrooster	1
Bakplaat	1		

Elektrische aansluiting

Aansluitwaarde	4800 W
Stroom	21 A
Spanning	220-240 V
Spanning 2 (V)	380-415 V
Electric cable	Installed, Single phase

Lengte voedingskabel	120 cm
Type stroomkabel	Double and Three Phase
Frequentie	50/60 Hz
Aansluitkast	5 polig

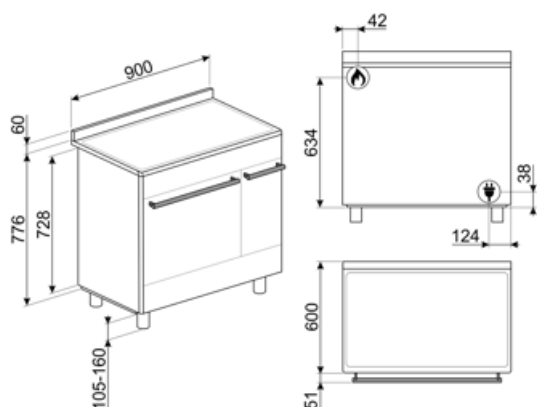

Accessoires niet inbegrepen

AIRFRY

Airfryerrek AIRFRY . Ideaal voor traditioneel frituren in de oven, maar met minder calorieën en minder vet. Hiermee creëer je snel en eenvoudig gerechten zoals frites, gebakken groenten en vis, waardoor ze perfect bruin en krokant worden.



BBQ

Dubbelzijdig



BN620-1

Geëmailleerde bakplaat, 20 mm diep



BNP608T

Teflon-coated tray, 8mm depth, to be placed on the grid



GTT

Volledig uittrekbare telescopische geleiders (1 niveau)



KITPC92X9

Splashback, 90cm, stainless steel, for Concerto cookers with double pyrolytic ovens

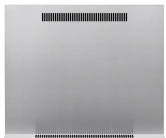

PALPZ

Pizzaschep met inklapbare handgreep breedte: 315 mm lengte: 325 mm



PRTX

Ronde pizzasteen met handvaten, diameter 35 cm



SMOLD

Set van 7 siliconen vormpjes voor ijsjes, ijslolly's, pralines, ijsblokjes of om etenswaren te portioneren. Bruikbaar van -60 ° C tot + 230 ° C

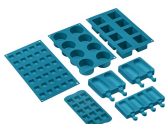

AL90X9

Opstand geschikt voor 90cm Concertofornuizen met gaskookplaat en MF oven



BG6090-1

Gietijzeren grillplaat geschikt voor Concerto fornuizen

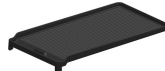

BN640

Geëmailleerde bakplaat, 40 mm diep



GTP

Gedeeltelijk uittrekbare telescopische geleiders (1 niveau)



KITH95

Hoogte uitbreidingsset (min.13cm - max.19,5cm), roestvrij staal



KITPDQ

Height reduction feet (850mm), stainless steel, for Concerto cookers (850-881mm)



PPX6090-1

Stainless steel teppanyaki plate, suitable for Concerto cookers



SFLK1

Kinderslot































STONE

Rectangular refractory stone Ideal for cooking pizzas with the same results as a typical wood-fired oven. Can also be used for baking bread, focaccias and other recipes such as pies, flans or biscuits Dimensions:L42 x H1,8 x P37,5 cm.



Symbols glossary (TT)

 <p>Heavy duty gietijzeren pannendragers: voor maximale stabiliteit en sterkte.</p>	 <p>A: Droogprestaties van het product, gemeten vanaf A +++ tot D / G afhankelijk van de productfamilie</p>
 <p>Installation in column: Installation in column</p>	 <p>Luchtkoelsysteem: om een veilig oppervlak te garanderen temperaturen.</p>
 <p>Deuren met driedubbele beglazing: aantal glazen deuren.</p>	 <p>Geëmailleerde binnenkant: De geëmailleerde binnenkant van alle Smeg-ovens heeft een speciale antacidumvoering die helpt om de binnenkant schoon te houden door de hoeveelheid kookvet te verminderen.</p>
 <p>Fan assisted base: the mix of fan and lower heating element alone allows to finish cooking foods already cooked on the surface but not internally more quickly. This system is recommended to finish cooking foods that are already well cooked on the surface, but not internally, which therefore require a moderate higher heat. Ideal for any type of food.</p>	 <p>Ventilator met bovenste en onderste elementen: de elementen in combinatie met de ventilator zijn bedoeld om een meer gelijkmatige warmte te bieden, een methode die vergelijkbaar is met conventioneel koken, dus voorverwarmen is vereist. Het meest geschikt voor items die langzaam koken vereisen.</p>
 <p>De ovenruimte wordt tegelijk door het onder- en bovinelement verwarmt. De hitteverdeling over het gerecht is afhankelijk van het niveau waarop men dit plaatst. Geschikt voor bakken op 1 niveau. Gerechten: alle ovenschotels, vlees, gevogelte, brood, (gevulde) taarten. Speciaal: gans en eend (bevatten veel vet).</p>	 <p>De ovenruimte wordt uitsluitend verhit door het onderelement. Voor gerechten die een hoge basistemperatuur behoeven, heeft deze bakstand weinig tot geen invloed op de korst aan de bovenzijde. Geschikt voor bakken op 1 niveau, ideaal voor deeggerechten die moeten rijzen (bijv. pizza). Bij gevulde taarten zal de deegbodem beter droog blijven.</p>
 <p>Circulaire: it is the perfect function for cooking all types of dishes in a more delicate way. The heat comes from the back of the oven and is distributed quickly and evenly The fan is active. It is also ideal for cooking on multiple levels without mixing smells and flavors.</p>	 <p>ECO: low energy consumption cooking: this function is particularly suitable for cooking on a single shelf with low energy consumption. It is recommended for all types of food except those that can generate a lot of moisture (for example vegetables). To achieve maximum energy savings and reduce time, it is recommended to put the food in the oven without preheating the cooking compartment</p>
 <p>De warmte wordt geproduceerd door het grill- en bovinelement. Verhitting over het volledige oppervlak. De thermostaat wordt, afhankelijk van het gerecht, in de regel op de maximale stand gezet. Bij een korte baktijd kan de ovendeur gesloten blijven; bij langere baktijd blijft deze gedeeltelijk geopend. Voor vleesgerechten (klein- en middelgroot), vleespennen, vis, groenten, gratineren etc.</p>	 <p>De warmte is alleen afkomstig van het grill-element. Verhitting over een kleiner oppervlak. Te gebruiken als de grote vlak-grill, maar voor kleinere hoeveelheden</p>
 <p>Gas ovens offer instantaneus heat control, reduced cooking times and the ability to bake at much lower temperatures than electric ovens.</p>	 <p>All glass inner door: All glass inner door, a single flat surface which is simple to keep clean.</p>

-
- | | | | |
|--|---|---|--|
|  | The inner door glass: can be removed with a few quick movements for cleaning. |  | verlichting |
|  | The oven cavity has 4 different cooking levels. |  | The oven cavity has 5 different cooking levels. |
|  | Telescopic rails: allow you to pull out the dish and check it without having to remove it from the oven entirely. |  | Electronic control: Allows you to maintain temperature inside the oven with the precision 2-3 ° C. This enables to cook meals that are very sensitive to temperature changes, such as cakes, souffles, puddings. |
|  | Tilting grill: the tilting grill can be easily unhooked to move the heating element and clean the roof of the appliance in one simple step. |  | Ultrasnelle branders: Krachtige ultrasnelle branders bieden tot 5kw vermogen. |
|  | Vapor Clean: a simple cleaning function using steam to loosen deposits in the oven cavity. |  | The capacity indicates the amount of usable space in the oven cavity in litres. |
|  | The capacity indicates the amount of usable space in the oven cavity in litres. |  | Knobs control |

Benefit (TT)

True-convection

The best cooking performances guaranteed by ventilated circular flow

Multiple fans and heating elements guarantee the perfect aerodynamic heat flow, allowing homogeneous and quicker cooking inside the cavity.

Gas hob

Gas provides permanent control of the heat source and the temperature change is immediate

Equipped with a thermocouple, the gas supply is cut off if the flame is extinguished for greater safety.

Vapor Clean

By inserting water into a recess at the bottom of the cavity, steam is generated, which softens the residue and facilitates its removal

By inserting water into a recess at the bottom of the cavity, steam is generated, which softens the residue and facilitates its removal.

Single turbine

The oven has a fan equipped with a circular heating element allowing cooking with rotating heat

Isothermic Cavity

The best cooking performance at the highest energy efficiency

Tangential cooling

New cooling system with tangential fan and airflow from the door to the splashback

Multilevel halogen light

Internal halogen lighting on different levels guarantees excellent visibility

Buttons control

Easy and intuitive timer setting with a simple buttons

Telescopic guides

Easy extraction and safe insertion of trays into the oven thanks to telescopic guides

Adjustable height

Cooker top flushed with the working area thanks to adjustable feet

Removable inner glass

Internal door glasses are easily removable for complete cleaning

Multilevel cooking

Several cooking levels allow maximum flexibility of use

Cold door

During any function, the external door glass is cold, avoiding any risk of burns

AirFry (AIRFRY optional accessory)

Lighter and tastier food thanks to airfry basket (optional accessory)

BBQ (optional accessory)

Barbeque cooking directly in the oven with the double-sided grill (BBQ optional accessory)

Pizza stone (optional accessory)

Baking with refractory stone for soft and crispy pizza and yeast products (STONE optional accessory)

Storage compartment

More space thanks to the lower compartment, ideal for storing accessories or cooking utensils