

# SX91GM

Categorie fornuis	90x60 cm
N. of cavities with energy label	1
Cavity heat source	Elektriciteit
Type kookplaat	Gas
Type primaire oven	Thermogeventileerd
EAN-code	8017709325039
Energie-efficiëntieklasse	A



## Design

			
<b>Design</b>	Standaard	<b>Bediening</b>	Bedieningsknoppen
<b>Afwerking bedieningspaneel</b>	Inox	<b>Bedieningsknoppen</b>	Smeg Classici
<b>Design</b>	Classici	<b>Kleur bedieningsknoppen</b>	Inox
<b>Logo</b>	In reliëf	<b>Aantal bedieningsknoppen</b>	8
<b>Kleur</b>	Inox	<b>Kleur serigrafie</b>	Zwart
<b>Positie logo</b>	Strook onder de oven	<b>Deur</b>	Geheel glas
<b>Afwerking</b>	Geborsteld inox	<b>Type glas</b>	Stopsol
<b>Series</b>	Concerto	<b>Handgreep</b>	Smeg Classici
<b>Kleur kookplaat</b>	Inox	<b>Kleur handgreep</b>	Geborsteld inox
<b>Type pottendragers</b>	Mat zwart geëmailleerd	<b>Pootjes</b>	Zilver

## Programma's / Functies

Aantal kookfuncties 6

Traditionele bereidingsfuncties



Statisch



Geventileerd



Turbo



ECO



Grote grill



Geventileerde onderwarmte

Overige functies



Ontdooien op tijd

## Reinigingsfuncties

 Vapor Clean reiniging

## Opties kookplaat

Timer 1

## Technische specificaties kookplaat

**UR**

Totaal aantal kookzones 5

Linksvoor - Gas - RP - 2.90 kW

Linksachter - Gas - SRD - 1.80 kW

Midden - Gas - URP - 4.00 kW

Rechtsachter - Gas - SRD - 1.80 kW

Rechtsvoor - Gas - AUX - 1.00 kW

Type gasbranders Standaard

Automatische vonkontsteking Ja

Thermobeveiliging

Ja

Branderdeksels

Mat zwart geëmailleerd

## Technische specificaties primaire oven



Aantal lampen 1

Aantal ventilatoren 1

Netto volume 1e oven 115 l

Bruto volume, oven 1 129 l

Materiaal ovenruimte Ever Clean emaille

Aantal kookniveaus 5

Type ovenrekken Metalen zijsteunen

Type licht Halogeen

Vermogen lamp 40 W

Opties bereidingstijdprogrammering Contaminuti + fine cottura

Opening deur Neerwaarts

Uitneembare ovendeur Ja

Volledig glazen binnendeur Ja

Uitneembaar glas binnendeur Ja

Aantal ruiten ovendeur 2

Aantal thermo-reflecterende ruiten 1

Veiligheidsthermostaat Ja

Koelsysteem Mantelkoeling

Afmetingen bruikbare interne ovenruimte (hxbxd) 371x724x418 mm

Temperatuurregeling Elektro-mechanisch

Onderwarmte - vermogen 1700 W

Bovenwarmte - vermogen 1200 W

Grill - vermogen 1700 W

Grote vlakgrill - vermogen 2900 W

Circulatie - vermogen 2000 W

Grill type Elektrisch

## Opties primaire oven

Maximum temperatuur 260 °C

Geluidssignaal einde kooktijd	Ja
Minimum temperatuur	50 °C

## Meegeleverde accessoires primaire oven en kookplaat

Houder t.b.v. caffettiera	1	Bakplaat (40 mm)	1
Ovenrooster met stop	1	Inzetrooster	1

## Elektrische aansluiting

Nominale aansluitwaarde	3200 W	Lengte voedingskabel	120 cm
Stroom	14 A	Frequentie	50/60 Hz
Spanning	220-240 V	Connection box	3 polig
Electric cable	Installed, Single phase	Stekker	Nee

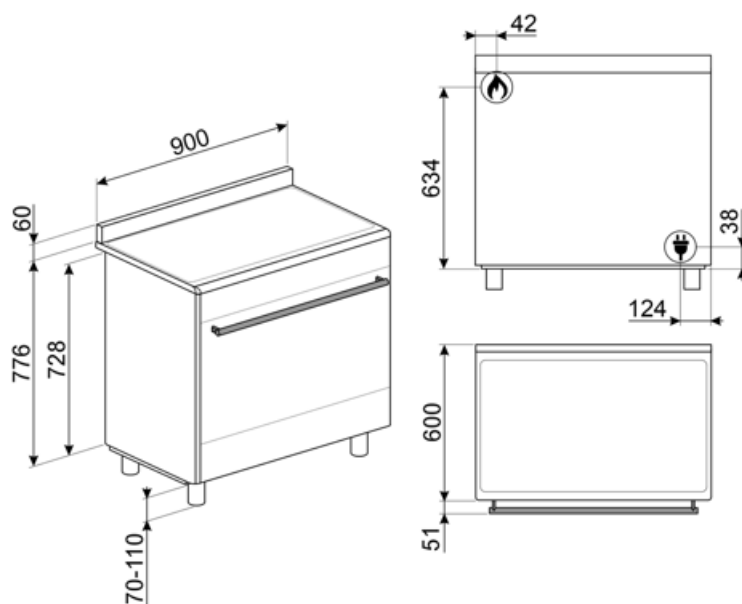

## Compatible Accessories

### AIRFRY9

Air fryer rack AIRFRY . Ideal for recreating traditional frying in the oven, but with fewer calories and less fat. It allows you to cook quickly and simply dishes such as French fries, fried vegetables and fish, ensuring perfect browning and crispiness.



### BBQ9

teflon-coated aluminum grid for 90 cm cavity



### BN940

Enamelled tray 90 cm, 40 mm deep



### GTT

Volledig uitschuifbare telescopische rails (1 niveau) voor traditionele ovens (SF-).



### KIT90X9-1

Splashback, stainless steel, 90cm, for Concerto cookers with single MF or gas oven



### KITPDQ

Height reduction feet (850mm), stainless steel, for Concerto cookers (850-881mm)



### SFLK1

Child lock



### AL90X9

Upstand suitable for 90cm Concert cookers with gas hob and MF oven



### BN920

Enamelled tray 90cm cavity, 20mm deep



### GTP

Partially extractable telescopic guides (1 level), suitable for traditional ovens. Made in stainless steel, they guarantee stability and facilitate the smooth extraction of the trays.



### KIT600SNL-9

Cover strip for hob back side, depth 60mm, suitable for 90cm single oven Concerto cookers



### KITH95

Height extension feet (950mm), stainless steel, suitable for Concerto cookers (911-966mm)



### PALPZ

Pizzapallet inox met plooibaar handvat, 315x325 mm







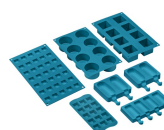









### SMOLD

Set van 7 siliconen vormen voor ijsjes, pralines, ijsblokjes of porties. -60°C tot 230°C.



## Symbols glossary

 Energy efficiency class A	 Installation in column: Installation in column.
 Air cooling system: to ensure a safe surface temperatures.	 Defrost by time: Manual defrost function. At the end of the set duration, the function stops.
 Double glazed doors: Number of glazed doors.	 Ever Clean Enamel: Ever Clean enamel is applied electrostatically, corner to corner and edge to edge to prevent cracking or cracks over time. It is a particular pyrolytic enamel, resistant to acids which, in addition to being pleasantly bright, promotes greater cleaning of the oven walls, thanks to its lower porosity. It is baked at over 850 °C and slowly polymerized at a scientifically determined rate to ensure uniform depth and strength. Ever Clean enamel creates an impeccable finish both on the inside of the oven and on the trays, making the surfaces of the oven incredibly easy to maintain over time as it reduces the adhesion of fat during cooking.
 Circogas: In gasovens verdeelt de ventilator de warmte snel en gelijkmatig over de ovenruimte, waardoor smaakoverdracht wordt vermeden bij het tegelijkertijd bereiden van een aantal verschillende gerechten. In elektrische ovens voltooit deze combinatie het koken van voedsel dat aan de oppervlakte klaar is, maar dat van binnen meer moet worden gekookt, zonder verder bruin te worden.	 Ventilator met bovenste en onderste elementen: De elementen in combinatie met de ventilator zijn bedoeld om een meer gelijkmatige warmte te bieden, een methode die vergelijkbaar is met conventioneel koken, dus voorverwarmen is vereist. Het meest geschikt voor items die langzaam koken vereisen.
 Alleen boven- en onder element: een traditionele kookmethode die het meest geschikt is voor losse items in het midden van de oven. de bovenkant van de oven zal altijd het heetst zijn. Ideaal voor gebraden vlees, fruitcake, brood etc.	 De combinatie van de grill, de ventilator en onderwarmte is interessant voor het bereiden van kleine hoeveelheden.
 Grill: Very intense heat coming only from above from a double heating element. The fan is not active. Provides excellent grilling and gratinating results. Used at the end of cooking, it gives a uniform browning to dishes.	 Circulaire met bovenste en onderste elementen: door het gebruik van de ventilator met beide elementen kan voedsel snel en effectief worden gekookt, ideaal voor grote stukken vlees die grondig moeten worden gekookt. Het biedt een vergelijkbaar resultaat als rotisserie, waarbij de warmte rond het voedsel wordt verplaatst in plaats van het voedsel zelf te verplaatsen, waardoor elke maat of vorm kan worden gekookt.
 All glass inner door: All glass inner door, a single flat surface which is simple to keep clean.	 The inner door glass: can be removed with a few quick movements for cleaning.



Side lights: Two opposing side lights increase visibility inside the oven.



Automatic opening: some models have Automatic opening door when the cycle is finished which is a perfect solution for handle-less kitchen units as no handle is needed. For safety reasons, the door locks automatically when the machine is in use to avoid it being opened inadvertently.



The oven cavity has 5 different cooking levels.



Ultra rapid burners: Powerful ultra rapid burners offer up to 5kw of power.



Vapor Clean: a simple cleaning function using steam to loosen deposits in the oven cavity.



The capacity indicates the amount of usable space in the oven cavity in litres.



Knobs control