

SY93-1

Cooker size	90x60 cm
N.º de cavidades com rótulo energético	2
Fonte de calor da cavidade	ELECTRICITY
Hob type	Gas
Tipo de forno principal	Thermo-ventilated
Type of second oven	Thermo-ventilated
Sistema de limpeza no forno principal	Vapor Clean
EAN code	8017709300500
Energy efficiency class	A
Energy efficiency class, second cavity	B



Aesthetics



Aesthetic	Classica	Type of control setting	Control knobs
Serie	Sinfonia	Control knobs	Smeg Classic
Design	Square design	Controls colour	Stainless steel
Colour	Stainless steel	No. of controls	9
Acabamento	Satin	Cor da serigrafia	Serigrafia em preto
Command panel finish	Stainless steel	Display	Touch
Logo	Logotipo serigrafado	Door	With 2 horizontal strips
Posição do logotipo	Logotipo no painel de comandos	Glass type	eclipse
Upstand	Yes	Handle	Smeg Classic
Cor da placa	Esmalte preto	Handle Colour	Brushed stainless steel
Type of pan stands	Cast Iron	Plinth	Black

Programs / Functions

No. of cooking functions 5

Traditional cooking functions

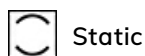

Static

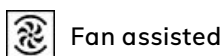

Fan assisted



Circulaire



Eco

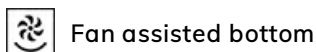

Fan assisted bottom

Other functions



Defrost by time

Cleaning functions

 Vapor clean



Programs / Functions Auxiliary Oven

Funções de cozedura cavidade 2 1
Funções tradicionais de cozimento, cavidade 2

 Circulaire

Defrost No
Vapor Clean No

Programs / Functions Third Oven

No. of functions third oven 1
Oven light 
Half grill No
Full grill 









Hob technical features

UR

Total no. of cook zones 5
Central esquerda - Gas - 2UR (dual) - 4.20 kW
Rear centre - Gas - Semi Rapid - 1.80 kW
Front centre - Gas - AUX - 1.00 kW
Rear right - Gas - Rapid - 2.90 kW
Front right - Gas - Semi Rapid - 1.80 kW

Type of gas burners	Standard	Gas safety valves	Yes
Automatic electronic ignition	Yes	Burner caps	Matt black enamelled

Main Oven Technical Features

							
No. of lights	1	Removable inner door	Yes				
Fan number	1	Total no. of door glasses	3				
Net volume of the cavity	61 l	No. of thermo-reflective door glasses	1				
Gross volume, 1st cavity	70 l	Safety Thermostat	Yes				
Cavity material	Ever Clean enamel	Cooling system	Tangential				
No. of shelves	4	Usable cavity space dimensions (HxWxD)	316x460x412 mm				
Type of shelves	Metal racks	Temperature control	Electro-mechanical				
Roof Liner	No						

Light type	Halogen	Lower heating element power	1200 W
Light Power	40 W	Upper heating element - Power	1000 W
Cooking time setting	Start and Stop	Grill element	1700 W
Door opening	Side opening	Large grill - Power	2700 W
Removable door	Yes	Circular heating element - Power	2000 W
Full glass inner door	Yes	Grill type	Electric
		Tilting grill	Yes

Options Main Oven

Timer	Yes	Minimum Temperature	50 °C
End of cooking acoustic alarm	Yes	Maximum temperature	260 °C

Second Oven Technical Features



Fan number	1	Full glass inner door	Yes
Net volume of the second cavity	62 l	Removable inner door	Yes
Gross volume, 2nd cavity	69 l	No. total door glasses	2
Cavity material	Ever Clean enamel	No. thermo-reflective door glasses	1
No. of shelves	9	Safety Thermostat	Yes
Type of shelves	Metal racks	Cooling system	Tangential
Roof Liner	No	Usable cavity space dimensions (HxWxD)	605x275x370 mm
No. of lights	1	Temperature control	Electro-mechanical
Light type	Halogen	Potência da resistência circular	2500 W
Light Power	40 W	Grill type	Electric
Door opening	Side opening	Tilting grill	No
Removable door	Yes		

Options Auxiliary Oven

Timer	No	Minimum Temperature	50 °C
End of cooking acoustic alarm	No	Maximum temperature	245 °C

Third Oven Technical Features



Net volume, 3rd cavity	36 l	Full glass inner door	Yes
Gross volume, 3rd cavity	41 l	Removable inner door	Yes
Cavity material	Ever Clean enamel	No. total door glasses	3

No. of shelves	2	No. of thermo-reflective door glasses	1
Type of shelves	Metal racks	Safety Thermostat	Yes
Roof Liner	No	Cooling system	Tangential
No. of lights	1	Usable cavity space dimensions (HxWxD)	169x440x443 mm
Light type	Halogen	Temperature control	Electro-mechanical
Light Power	40 W	Large grill - Power	2700 W
Door opening	Flap down	Grill type	Electric
Removable door	Yes	Tilting grill	Yes

Options Third Oven

Timer	No	Minimum Temperature	50 °C
End of cooking acoustic alarm	No	Maximum temperature	260 °C

Accessories included for Main Oven & Hob



Cast iron wok support	1	40mm deep tray	1
Moka stand in cast iron	1	Grill mesh	1
Rack com batente traseiro e lateral	2	Telescopic Guide rails, partial Extraction	1

Accessories included for Secondary Oven



Oven grid with back stop	4	Plate rack/warmer	1
--------------------------	---	-------------------	---

Accessories included for Third Oven

Rack com batente traseiro e lateral	1	40mm deep tray	1
-------------------------------------	---	----------------	---

Electrical Connection

Plug	No	Electric cable	Installed, Single phase
Electrical connection rating	7600 W	Type of electric cable	Double and Three Phase
Current	33 A	Frequency	50/60 Hz
Voltage	220-240 V	Bloco de terminais	5 polos

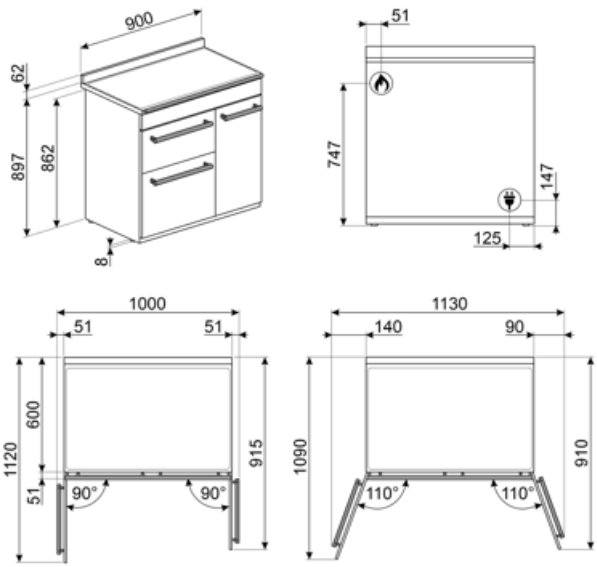

Compatible Accessories

AIRFRY

Air fryer rack AIRFRY . Ideal for recreating traditional frying in the oven, but with fewer calories and less fat. It allows you to cook quickly and simply dishes such as French fries, fried vegetables and fish, ensuring perfect browning and crispiness.



BGTR9

Placa para grelhar de ferro fundido adequada para fogões Victoria 90 cm, Master e Sinfonia de 60 e 90 cm



BN640

Tabuleiro esmaltado, 40mm de profundidade

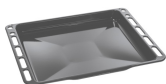

GTP

** Guias telescópicas parcialmente extraíveis (1 nível)** Extração: 300 mm
Material: Aço inoxidável AISI 430 polido



KITC9X9-1

Painel anti-salpicos, 90x75 cm, aço inoxidável, adequado para fogões Portofino, Master e Sinfonia

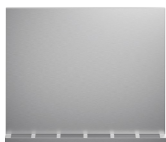

PALPZ

Pá para pizza com alça dobrável largura: 315mm comprimento : 325mm



SMOLD

Conjunto de 7 moldes de silicone para sorvetes, gelados, pralinés, cubos de gelo ou para porção de alimentos. Utilizável de -60°C a +230°C

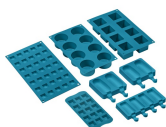

BBQ

Double sided plate BBQ. Suitable for recreating succulent and crispy dishes in the oven with the typical taste of grilled cooking. The ribbed side is particularly suitable for meats and cheeses. The smooth side for fish, seafood and vegetables.



BN620-1

Tabuleiro esmaltado, 20mm de profundidade



BNP608T

Bandeja revestida de teflon, 8mm de profundidade, a ser colocada na grade



GTT

** Guias telescópicas totalmente extraíveis (1 nível)** Extração: 433 mm
Material: Aço inoxidável AISI 430 polido



KITPBX

Pés de redução de altura (850 mm)



































SFLK1

Bloqueio para crianças



Symbols glossary

	Suportes de ferro fundido para serviço pesado: para máxima estabilidade e resistência.		R: Desempenho de secagem do produto, medido de A++ a D/G, dependendo da família de produtos
	Instalação em coluna: Instalação em coluna		Controle dos botões
	Sistema de arrefecimento a ar: para garantir temperaturas de superfície seguras.		Descongela pelo tempo: com esta função, o tempo de descongelamento dos alimentos é determinado automaticamente.
	B: Classificação de energia do produto, medida de A+++ a D/G, dependendo da família de produtos.		Portas de vidros duplos: Número de portas envidraçadas.
	Portas envidraçadas triplas: Número de portas envidraçadas.		Interior esmaltado: O interior em esmalte de todos os fornos Smeg tem um revestimento antiácido especial que ajuda a manter o interior limpo, reduzindo a quantidade de gordura de cozimento aderente a ele.
	Circogas: Em fornos a gás, o ventilador distribui o calor de forma rápida e uniforme por toda a cavidade do forno, evitando a transferência de sabor ao cozinhar vários pratos diferentes ao mesmo tempo. Em fornos elétricos, esta combinação completa o cozimento mais rapidamente de alimentos que estão prontos na superfície, mas que exigem mais cozimento no interior, sem mais escurecimento.		Ventilador com elementos superiores e inferiores: Os elementos combinados com o ventilador visam fornecer calor mais uniforme, um método semelhante ao cozimento convencional, de modo que o pré-aquecimento é necessário. Mais adequado para itens que exigem métodos de cozimento lento.
	Somente elementos superior e inferior: um método de cozimento tradicional mais adequado para itens individuais localizados no centro do forno. A parte superior do forno será sempre mais quente. Ideal para assados, bolos de frutas, pão, etc.		Circulaire: A combinação do ventilador e do elemento circular em torno dele dá um método de cozimento de ar quente. Isso oferece muitos benefícios, incluindo nenhum pré-aquecimento se o tempo de cozimento for superior a 20 minutos, nenhuma transferência de sabor ao cozinhar alimentos diferentes ao mesmo tempo, menos energia e tempos de cozimento mais curtos. Bom para todos os tipos de alimentos.
	ECO: A combinação da grelha, ventilador e elemento inferior é particularmente adequada para cozinhar pequenas quantidades de alimentos.		Elemento de grelha O uso de grelha dá excelentes resultados ao cozinhar carne de porções médias e pequenas, especialmente quando combinada com uma rotisseria (sempre que possível). Também é ideal para cozinhar salsichas e bacon.
	Luz		Toda a porta interna de vidro: Toda a porta interna de vidro, uma única superfície plana que é simples de manter limpa.
	O vidro interior da porta: pode ser removido com alguns movimentos rápidos para limpeza.		Luzes laterais: Duas luzes laterais opostas aumentam a visibilidade dentro do forno.

-
- | | | | |
|---|---|---|---|
|  | Aquecimento: Uma opção para aquecer o prato e manter as refeições preparadas quentes. |  | O compartimento do forno tem 2 níveis de cozimento diferentes. |
|  | O compartimento do forno tem 4 níveis de cozimento diferentes. |  | O compartimento do forno tem 9 níveis de cozimento diferentes. |
|  | Trilhos telescópicos: permitem puxar o prato e verificá-lo sem ter que removê-lo completamente do forno. |  | Comando eletrônico. Permite manter a temperatura no interior do forno com a precisão de 2-3 ° C. Isso permite cozinhar refeições que são muito sensíveis a mudanças de temperatura, como por ex. bolos, suflês, pudins. |
|  | Grelha basculante: a grelha basculante pode ser facilmente desengatada para mover o elemento de aquecimento e limpar o tejadilho do aparelho em um simples passo. |  | Queimadores ultrarrápidos: Queimadores ultrarrápidos potentes oferecem até 5kw de potência. |
|  | Limpeza a Vapor: uma função de limpeza simples que utiliza vapor para afrouxar os depósitos no compartimento do forno. |  | A capacidade indica a quantidade de espaço útil no compartimento do forno em litros. |
|  | A capacidade indica a quantidade de espaço útil no compartimento do forno em litros. |  | A capacidade indica a quantidade de espaço útil no compartimento do forno em litros. |
|  | ... | | |

Benefit (TT)

Gas hob

Gas provides permanent control of the heat source and the temperature change is immediate

Equipped with a thermocouple, the gas supply is cut off if the flame is extinguished for greater safety.

Vapor Clean

By inserting water into a recess at the bottom of the cavity, steam is generated, which softens the residue and facilitates its removal

By inserting water into a recess at the bottom of the cavity, steam is generated, which softens the residue and facilitates its removal.

Touch control

Easy and intuitive timer setting with a single touch

True-convection

The best cooking performances guaranteed by ventilated circular flow

Multiple fans and heating elements guarantee the perfect aerodynamic heat flow, allowing homogeneous and quicker cooking inside the cavity.

Multilevel cooking

Several cooking levels allow maximum flexibility of use

Multilevel halogen light

Internal halogen lighting on different levels guarantees excellent visibility

Removable inner glass

Internal door glasses are easily removable for complete cleaning

Tangential cooling

New cooling system with tangential fan and airflow from the door to the splashback

Telescopic guides

Easy extraction and safe insertion of trays into the oven thanks to telescopic guides

BBQ (optional accessory)

Barbeque cooking directly in the oven with the double-sided grill (BBQ optional accessory)

Pizza stone (optional accessory)

Baking with refractory stone for soft and crispy pizza and yeast products (STONE optional accessory)

Isothermic Cavity

The best cooking performance at the highest energy efficiency

Cold door

During any function, the external door glass is cold, avoiding any risk of burns

AirFry (AIRFRY optional accessory)

Lighter and tastier food thanks to airfry basket (optional accessory)

Adjustable height

Cooker top flushed with the working area thanks to adjustable feet

Single turbine

The oven has a fan equipped with a circular heating element allowing cooking with rotating heat