

TR103IBL2

Categorie fornuis	100x60 cm
N. of cavities with energy label	2
Cavity heat source	Elektriciteit
Type kookplaat	Inductie
Type primaire oven	Thermogeventileerd
Type secundaire oven	Thermogeventileerd
Reinigingssysteem primaire oven	Vapor Clean reiniging
EAN-code	8017709312404
Energie-efficiëntieklasse	A
Energie-efficiëntieklasse, tweede oven	B



Design

			
Design	Victoria	Bedieningsknoppen	Smeg Victoria
Design	Victoria	Kleur	Inox
Kleur	Zwart	bedieningsknoppen	
Afwerking	Glanzend	Aantal	9
Afwerking	Gekleurd plaatstaal	bedieningsknoppen	
bedieningspaneel		Kleur serigrafie	Zilver
Logo	assembled 50's	Display	Elektronisch 5 toetsen
Positie logo	Upstand+	Deur	Met kader
	Bedieningspaneel	Type glas	Zwart
Upstand	Ja	Handgreep	Smeg Victoria
Kleur kookplaat	Black enamel	Kleur handgreep	Geborsteld inox
Bediening	Bedieningsknoppen	Plint	Antraciet

Programma's / Functies

Aantal kookfuncties 6

Traditionele bereidingsfuncties

Geventileerde onderwarmte + Vapor

clean



Circulatie (ventilator + circulaire)



Overige functies

 Ontdooien op tijd

Reinigingsfuncties

 Vapor Clean reiniging

Programma's / Functies secundaire oven

Aantal kookfuncties 1

Traditionele bereidingsfuncties, 2e oven



Circulatie (ventilator + circulaire)

Programma's / Functies derde oven

Aantal functies derde oven 1

Licht 

Grote vlakgrill 

Technische specificaties kookplaat

Totaal aantal kookzones 5

Linksvoor - Inductie - enkel - 1.30 kW - Booster 1.40 kW - - Ø 21.0 cm

Linksachter - Inductie - enkel - 2.30 kW - Booster 3.00 kW - - Ø 18.0 cm

Midden - Inductie - enkel - 2.30 kW - Booster 3.00 kW - - Ø 27.0 cm

Rechtsachter - Inductie - enkel - 1.30 kW - Booster 1.40 kW - - Ø 18.0 cm

Rechtsvoor - Inductie - enkel - 2.30 kW - Booster 3.00 kW - - Ø 21.0 cm

Technische specificaties primaire oven



Aantal lampen	1	Uitneembare ovendeur	Ja
Aantal ventilatoren	1	Volledig glazen binnendeur	Ja
Netto volume 1e oven	61 l	Aantal ruiten ovendeur	3
Bruto volume, oven 1	70 l	Aantal thermo-reflecterende ruiten	1
Materiaal ovenruimte	Ever Clean emaille	Veiligheidsthermostaat	Ja
Aantal kookniveaus	4	Koelsysteem	Mantelkoeling
Type ovenrekken	Metalen zijsteunen	Afmetingen bruikbare interne ovenruimte (hxbxd)	316x460x412 mm
Type licht	Halogeen	Temperatuurregeling	Elektro-mechanisch
Vermogen lamp	40 W		
Opties bereidingstijdprogrammering	Begin en eind		

Opening deur	Side opening	Onderwarmte - vermogen	1200 W
		Bovenwarmte - vermogen	1000 W
		Circulatie - vermogen	2000 W

Opties primaire oven

Timer	Ja	Minimum temperatuur	50 °C
Geluidssignaal einde kooktijd	Ja	Maximum temperatuur	250 °C

Technische specificaties secundaire oven



Aantal ventilatoren	2	Uitneembare ovendeur	Ja
Netto volume 2e oven	84 l	Volledig glazen binnendeur	Ja
Bruto volume, oven 2	94 l	Uitneembaar glas binnendeur	Ja
Materiaal ovenruimte	Ever Clean emaille	Aantal ruiten ovendeur	2
Aantal kookniveaus	9	Aantal thermo-reflecterende ruiten	1
Type ovenrekken	Metalen zijsteunen	Veiligheidsthermostaat	Ja
Aantal lampen	1	Koelsysteem	Mantelkoeling
Type lamp	Halogeen	Afmetingen bruikbare interne ovenruimte (hxbxd)	605x375x375 mm
Vermogen lamp	40 W	Temperatuurregeling	Elektro-mechanisch
Opening deur	Side opening	Circulatie - vermogen	2 x 1550 W

Opties secundaire oven

Minimum temperatuur	50 °C	Maximum temperatuur	245 °C
---------------------	-------	---------------------	--------

Technische specificaties derde oven



Netto volume, 3e oven	36 l	Uitneembaar glas binnendeur	Ja
Bruto volume, oven 3	41 l	Aantal ruiten ovendeur	3
Materiaal ovenruimte	Ever Clean emaille	Aantal thermo-reflecterende ruiten	1
Aantal kookniveaus	2	Veiligheidsthermostaat	Ja
Type ovenrekken	Metalen zijsteunen	Koelsysteem	Mantelkoeling
Aantal lampen	1	Afmetingen bruikbare interne ovenruimte (hxbxd)	169x440x443 mm
Type lamp	Halogeen	Temperatuurregeling	Elektro-mechanisch
Vermogen lamp	40 W		
Opening deur	Neerwaarts		
Uitneembare ovendeur	Ja		

Volledig glazen binnendeur	Ja	Grote vlakgrill - vermogen	2700 W
		Type grill	Elektrisch
		Kantelbare grill	Ja

Opties derde oven

Minimum temperatuur	50 °C	Maximum temperatuur	260 °C
---------------------	-------	---------------------	--------

Meegeleverde accessoires primaire oven en kookplaat



Ovenrooster met stop	2	Inzetrooster	1
Bakplaat (40 mm)	1	Telescopische geleiders, gedeeltelijk uitschuifbaar	1

Meegeleverde accessoires secundaire oven



Ovenrooster met stop	4	Bordenwarmhouder	1
----------------------	---	------------------	---

Meegeleverde accessoires derde oven

Ovenrooster met stop	1	Bakplaat (40 mm)	1
----------------------	---	------------------	---

Elektrische aansluiting

Nominale aansluitwaarde	15400 W	Lengte voedingskabel	150 cm
Stroom	43 A	Type stroomkabel	Double and Three Phase
Spanning	220-240 V	Frequentie	50/60 Hz
Spanning 2 (V)	380-415 V	Connection box	5 polig
Electric cable	Installed, Single phase		

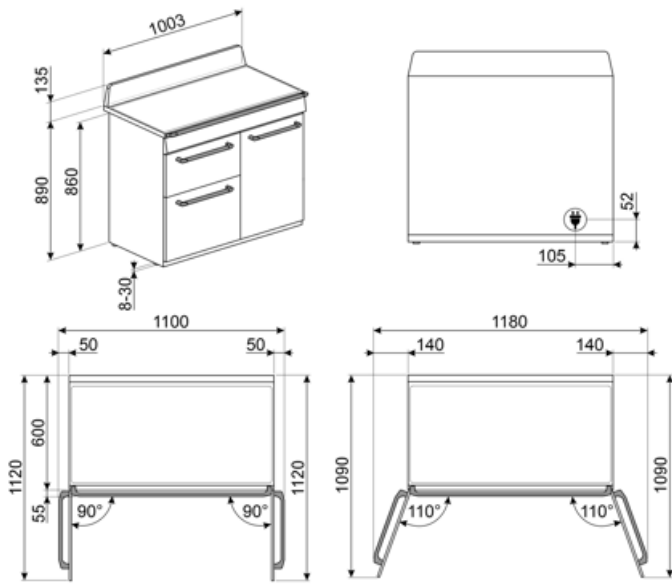

Compatible Accessories

AIRFRY



BN620-1

Enamelled tray suitable for 45cm and 60cm ovens. Depth 20 mm. Perfect for a wide range of savoury and sweet baking.



BNP608T

Teflon bakplaat, 8mm diep



GTP

Partially extractable telescopic guides (1 level), suitable for traditional ovens. Made in stainless steel, they guarantee stability and facilitate the smooth extraction of the trays.



KIT1TR103

Splashback black, 100cm, suitable for TR103 Victoria cookers



PALPZ

Pizzapallet inox met plooibaar handvat, 315x325 mm



SFLK1

Child lock



TPKPLATE

Universal plate for induction, gas, ceramic and electric hobs. Non-stick surface ideal for cooking fish, eggs and vegetables. Dimensions: 410 X 240 mm.



BBQ

Dubbelzijdig



BN640

Enamelled tray suitable for 45cm and 60cm ovens. Depth 540 mm. Perfect for cooking and roasting meat and fish in sauces. Also ideal for experimenting with lighter and crunchy side dishes



GRILLPLATE

Universal griddle for induction, gas, ceramic and electric hobs. Non-stick surface ideal for cooking meat, cheese and vegetables. Dimensions: 410 x 240 mm.



GTT

Volledig uitschuifbare telescopische rails (1 niveau) voor traditionele ovens (SF-).



KITH103

Height extension kit (950 mm), black, suitable for TR103 cookers (945-960mm)



SCRP

Schraper voor inductie- en vitrokeramische kookplaten







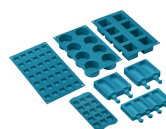

























SMOLD

Set van 7 siliconen vormen voor ijsjes, pralines, ijsblokjes of porties. -60°C tot 230°C.



Symbols glossary

			B: Product energy rating, measured from A+++ to D / G depending on the product family.
	Sommige modellen zijn voorzien van een functie om het programma/de cyclus te blokkeren zodat het niet per ongeluk kan aangepast worden.		Installation in column: Installation in column
	Air cooling system: to ensure a safe surface temperatures.		Defrost by time: Manual defrost function. At the end of the set duration, the function stops.
	Double glazed doors: Number of glazed doors.		Triple glazed doors: Number of glazed doors.
	ECO-logic: option allows you to restrict the power limit of the appliance real energy saving.		Ever Clean Enamel: Ever Clean enamel is applied electrostatically, corner to corner and edge to edge to prevent cracking or cracks over time. It is a particular pyrolytic enamel, resistant to acids which, in addition to being pleasantly bright, promotes greater cleaning of the oven walls, thanks to its lower porosity. It is baked at over 850 ° C and slowly polymerized at a scientifically determined rate to ensure uniform depth and strength Ever Clean enamel creates an impeccable finish both on the inside of the oven and on the trays, making the surfaces of the oven incredibly easy to maintain over time as it reduces the adhesion of fat during cooking
	Ventilator met bovenste en onderste elementen: De elementen in combinatie met de ventilator zijn bedoeld om een meer gelijkmatige warmte te bieden, een methode die vergelijkbaar is met conventioneel koken, dus voorverwarmen is vereist. Het meest geschikt voor items die langzaam koken vereisen.		Alleen boven- en onder element: een traditionele kookmethode die het meest geschikt is voor losse items in het midden van de oven. de bovenkant van de oven zal altijd het heetst zijn. Ideaal voor gebraden vlees, fruitcake, brood etc.
	Circulaire: De combinatie van de ventilator en het ronde element eromheen zorgt voor een hete lucht kookmethode. Dit biedt vele voordelen, waaronder geen voorverwarmen als de kooktijd meer dan 20 minuten bedraagt, geen smaakoverdracht bij het gelijktijdig bereiden van verschillende soorten voedsel, minder energie en kortere kooktijden. Geschikt voor alle soorten voedsel.		De combinatie van de grill, de ventilator en onderwarmte is interessant voor het bereiden van kleine hoeveelheden.
	Grill element: Using of grill gives excellent results when cooking meat of medium and small portions, especially when combined with a rotisserie (where possible). Also ideal for cooking sausages and bacon.		Light
	Induction: The work of these hobs is based on the principle of electromagnetic induction. The heat is generated directly in the bottom of the pan during its contact with the hob.		All glass inner door: All glass inner door, a single flat surface which is simple to keep clean.

-
-  Side lights: Two opposing side lights increase visibility inside the oven.
 -  Plate rack warming: function for heating or keeping dishes warm. Place the baking tray on the lowest shelf and stack the dishes to be heated.
 -  The oven cavity has 2 different cooking levels.
 -  The oven cavity has 4 different cooking levels.
 -  The oven cavity has 9 different cooking levels.
 -  Telescopic rails: allow you to pull out the dish and check it without having to remove it from the oven entirely.
 -  Electronic control: Allows you to maintain temperature inside the oven with the precision 2-3 ° C. This enables to cook meals that are very sensitive to temperature changes, such as cakes, souffles, puddings.
 -  Tilting grill: the tilting grill can be easily unhooked to move the heating element and clean the roof of the appliance in one simple step.
 -  Vapor Clean: a simple cleaning function using steam to loosen deposits in the oven cavity.
 -  The capacity indicates the amount of usable space in the oven cavity in litres.
 -  The capacity indicates the amount of usable space in the oven cavity in litres.
 -  The capacity indicates the amount of usable space in the oven cavity in litres.
 -  Knobs control

Benefit (TT)

Induction hob

Induction offers fast cooking and precise temperature control

Through the use of suitable cookware, induction is easy to use and maintain, safe and responsive.

Vapor Clean

By inserting water into a recess at the bottom of the cavity, steam is generated, which softens the residue and facilitates its removal

By inserting water into a recess at the bottom of the cavity, steam is generated, which softens the residue and facilitates its removal.

Buttons control

Easy and intuitive timer setting with a simple buttons

True-convection

The best cooking performances guaranteed by ventilated circular flow

Multiple fans and heating elements guarantee the perfect aerodynamic heat flow, allowing homogeneous and quicker cooking inside the cavity.

Multilevel cooking

Several cooking levels allow maximum flexibility of use

Multilevel halogen light

Internal halogen lighting on different levels guarantees excellent visibility

Tangential cooling

New cooling system with tangential fan and airflow from the door to the splashback

Telescopic guides

Easy extraction and safe insertion of trays into the oven thanks to telescopic guides

Isothermic Cavity

The best cooking performance at the highest energy efficiency

BBQ (optional accessory)

Barbeque cooking directly in the oven with the double-sided grill (BBQ optional accessory)

Pizza stone (optional accessory)

Baking with refractory stone for soft and crispy pizza and yeast products (STONE optional accessory)

Adjustable height

Cooker top flushed with the working area thanks to adjustable feet

Cold door

During any function, the external door glass is cold, avoiding any risk of burns

AirFry (AIRFRY optional accessory)

Lighter and tastier food thanks to airfry basket (optional accessory)

Single turbine

The oven has a fan equipped with a circular heating element allowing cooking with rotating heat