

# TR103IGR2

Categorie fornuis	100x60 cm
N. of cavities with energy label	2
Cavity heat source	Elektriciteit
Type kookplaat	Inductie
Type primaire oven	Thermogeventileerd
Type secundaire oven	Thermogeventileerd
Reinigingssysteem primaire oven	Vapor Clean reiniging
EAN-code	8017709312428
Energie-efficiëntieklasse	A
Energie-efficiëntieklasse, tweede oven	B



## Design

			
Design	Victoria	Bedieningsknoppen	Smeg Victoria
Design	Victoria	Kleur	Inox
Kleur	Leigrijs	bedieningsknoppen	
Afwerking	Glanzend	Aantal	9
Afwerking	Gekleurd plaatstaal	bedieningsknoppen	
bedieningspaneel		Kleur serigrafie	Zwart
Logo	assembled 50's	Display	Elektronisch 5 toetsen
Positie logo	Upstand+	Deur	Met kader
	Bedieningspaneel	Type glas	Zwart
Upstand	Ja	Handgreep	Smeg Victoria
Kleur kookplaat	Black enamel	Kleur handgreep	Geborsteld inox
Bediening	Bedieningsknoppen	Plint	Antraciet

## Programma's / Functies

Aantal kookfuncties	5
Traditionele bereidingsfuncties	



Statisch



Geventileerd



Circulatie (ventilator + circulaire)



ECO



Geventileerde onderwarmte

### Overige functies

 Ontdooien op tijd

### Reinigingsfuncties

 Vapor Clean reiniging

## Programma's / Functies secundaire oven

Aantal kookfuncties 1

Traditionele bereidingsfuncties, 2e oven



Circulatie (ventilator + circulaire)

## Programma's / Functies derde oven

Aantal functies derde oven 1

Licht 

Grote vlakgrill 

## Technische specificaties kookplaat

Totaal aantal kookzones 5

Linksvoor - Inductie - enkel - 1.30 kW - Booster 1.40 kW - - Ø 21.0 cm

Linksachter - Inductie - enkel - 2.30 kW - Booster 3.00 kW - - Ø 18.0 cm

Midden - Inductie - enkel - 2.30 kW - Booster 3.00 kW - - Ø 27.0 cm

Rechtsachter - Inductie - enkel - 1.30 kW - Booster 1.40 kW - - Ø 18.0 cm

Rechtsvoor - Inductie - enkel - 2.30 kW - Booster 3.00 kW - - Ø 21.0 cm

## Technische specificaties primaire oven



Aantal lampen 1

Aantal ventilatoren 1

Netto volume 1e oven 61 l

Bruto volume, oven 1 70 l

Materiaal ovenruimte Ever Clean emaille

Aantal kookniveaus 4

Type ovenrekken Metalen zijsteunen

Type licht Halogeen

Vermogen lamp 40 W

Opties  
bereidingstijdprogrammering Begin en eind

Aantal ruiten ovendeur 3

Aantal thermo-

reflecterende ruiten 1

Veiligheidsthermostaat Ja

Koelsysteem Mantelkoeling

Afmetingen bruikbare  
interne ovenruimte  
(hxbxd) 316x460x412 mm

Temperatuurregeling Elektro-mechanisch

Onderwarmte -  
vermogen 1200 W

Opening deur	Side opening	Bovenwarmte - vermogen	1000 W
Uitneembare ovendeur	Ja	Grill - vermogen	1700 W
Volledig glazen binnendeur	Ja	Grote vlakgrill - vermogen	2700 W
		Circulatie - vermogen	2000 W
		Grill type	Elektrisch
		Kantelbare grill	Ja

## Opties primaire oven

Timer	Ja	Minimum temperatuur	50 °C
Geluidssignaal einde kooktijd	Ja	Maximum temperatuur	250 °C

## Technische specificaties secundaire oven



Aantal ventilatoren	2	Uitneembare ovendeur	Ja
Netto volume 2e oven	84 l	Volledig glazen binnendeur	Ja
Bruto volume, oven 2	94 l	Uitneembaar glas binnendeur	Ja
Materiaal ovenruimte	Ever Clean emaille	Aantal ruiten ovendeur	2
Aantal kookniveaus	9	Aantal thermo-reflecterende ruiten	1
Type ovenrekken	Metalen zijsteunen	Veiligheidsthermostaat	Ja
Aantal lampen	1	Koelsysteem	Mantelkoeling
Type lamp	Halogeen	Afmetingen bruikbare interne ovenruimte (hxbxd)	605x375x375 mm
Vermogen lamp	40 W	Temperatuurregeling	Elektro-mechanisch
Opening deur	Side opening	Circulatie - vermogen	2 x 1550 W

## Opties secundaire oven

Minimum temperatuur	50 °C	Maximum temperatuur	245 °C
---------------------	-------	---------------------	--------

## Technische specificaties derde oven



Netto volume, 3e oven	36 l	Uitneembaar glas binnendeur	Ja
Bruto volume, oven 3	41 l	Aantal ruiten ovendeur	3
Materiaal ovenruimte	Ever Clean emaille	Aantal thermo-reflecterende ruiten	1
Aantal kookniveaus	2	Veiligheidsthermostaat	Ja
Type ovenrekken	Metalen zijsteunen	Koelsysteem	Mantelkoeling
Aantal lampen	1		
Type lamp	Halogeen		

Vermogen lamp	40 W	Afmetingen bruikbare interne ovenruimte (hxbxd)	169x440x443 mm
Opening deur	Neerwaarts	Temperatuurregeling	Elektro-mechanisch
Uitneembare ovendeur	Ja	Grote vlakgrill - vermogen	2700 W
Volledig glazen binnendeur	Ja	Type grill	Elektrisch
		Kantelbare grill	Ja

## Opties derde oven

Minimum temperatuur	50 °C	Maximum temperatuur	260 °C
---------------------	-------	---------------------	--------

## Meegeleverde accessoires primaire oven en kookplaat



Ovenrooster met stop	2	Inzetrooster	1
Bakplaat (40 mm)	1	Telescopische geleiders, gedeeltelijk uitschuifbaar	1

## Meegeleverde accessoires secundaire oven



Ovenrooster met stop	4	Bordenwarmhouder	1
----------------------	---	------------------	---

## Meegeleverde accessoires derde oven

Ovenrooster met stop	1	Bakplaat (40 mm)	1
----------------------	---	------------------	---

## Elektrische aansluiting

Nominale aansluitwaarde	15400 W	Lengte voedingskabel	150 cm
Stroom	43 A	Type stroomkabel	Double and Three Phase
Spanning	220-240 V	Frequentie	50/60 Hz
Spanning 2 (V)	380-415 V	Connection box	5 polig
Electric cable	Installed, Single phase		

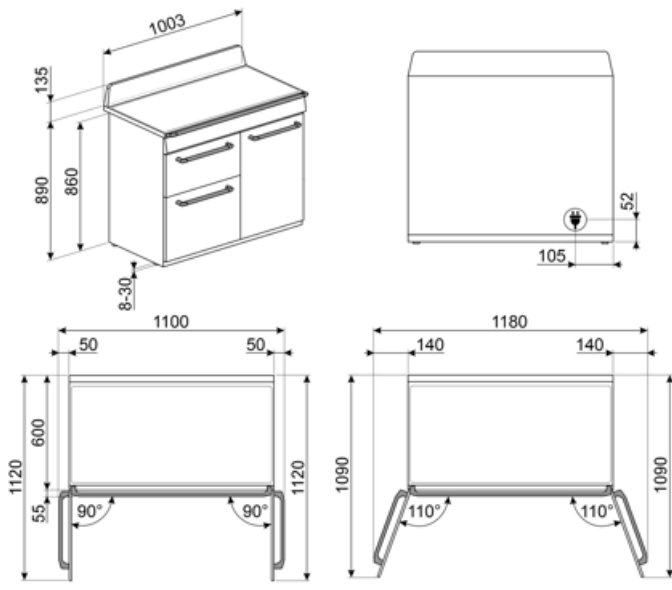

## Compatible Accessories

### AIRFRY



#### BN620-1

Enamelled tray suitable for 45cm and 60cm ovens. Depth 20 mm. Perfect for a wide range of savoury and sweet baking.



#### BNP608T

Teflon bakplaat, 8mm diep



#### GTP

Partially extractable telescopic guides (1 level), suitable for traditional ovens. Made in stainless steel, they guarantee stability and facilitate the smooth extraction of the trays.



#### KIT1TR103

Splashback black, 100cm, suitable for TR103 Victoria cookers



#### PALPZ

Pizzapallet inox met plooibaar handvat, 315x325 mm



#### SFLK1

Child lock



#### TPKPLATE

Universal plate for induction, gas, ceramic and electric hobs. Non-stick surface ideal for cooking fish, eggs and vegetables. Dimensions: 410 X 240 mm.



### BBQ

Dubbelzijdig



#### BN640

Enamelled tray suitable for 45cm and 60cm ovens. Depth 540 mm. Perfect for cooking and roasting meat and fish in sauces. Also ideal for experimenting with lighter and crunchy side dishes



#### GRILLPLATE

Universal griddle for induction, gas, ceramic and electric hobs. Non-stick surface ideal for cooking meat, cheese and vegetables. Dimensions: 410 x 240 mm.



#### GTT

Volledig uitschuifbare telescopische rails (1 niveau) voor traditionele ovens (SF-).



#### KITH103

Height extension kit (950 mm), black, suitable for TR103 cookers (945-960mm)



#### SCRP

Schraper voor inductie- en vitrokeramische kookplaten







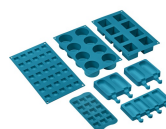



























#### SMOLD

Set van 7 siliconen vormen voor ijsjes, pralines, ijsblokjes of porties. -60°C tot 230°C.



## Symbols glossary

	 <p>B: Product energy rating, measured from A+++ to D / G depending on the product family.</p>
 <p>Sommige modellen zijn voorzien van een functie om het programma/de cyclus te blokkeren zodat het niet per ongeluk kan aangepast worden.</p>	 <p>Installation in column: Installation in column</p>
 <p>Air cooling system: to ensure a safe surface temperatures.</p>	 <p>Defrost by time: Manual defrost function. At the end of the set duration, the function stops.</p>
 <p>Double glazed doors: Number of glazed doors.</p>	 <p>Triple glazed doors: Number of glazed doors.</p>
 <p>ECO-logic: option allows you to restrict the power limit of the appliance real energy saving.</p>	 <p>Ever Clean Enamel: Ever Clean enamel is applied electrostatically, corner to corner and edge to edge to prevent cracking or cracks over time. It is a particular pyrolytic enamel, resistant to acids which, in addition to being pleasantly bright, promotes greater cleaning of the oven walls, thanks to its lower porosity. It is baked at over 850 ° C and slowly polymerized at a scientifically determined rate to ensure uniform depth and strength Ever Clean enamel creates an impeccable finish both on the inside of the oven and on the trays, making the surfaces of the oven incredibly easy to maintain over time as it reduces the adhesion of fat during cooking</p>
 <p>Circogas: In gasovens verdeelt de ventilator de warmte snel en gelijkmatig over de ovenruimte, waardoor smaakoverdracht wordt vermeden bij het tegelijkertijd bereiden van een aantal verschillende gerechten. In elektrische ovens voltooit deze combinatie het koken van voedsel dat aan de oppervlakte klaar is, maar dat van binnen meer moet worden gekookt, zonder verder bruin te worden.</p>	 <p>Ventilator met bovenste en onderste elementen: De elementen in combinatie met de ventilator zijn bedoeld om een meer gelijkmatige warmte te bieden, een methode die vergelijkbaar is met conventioneel koken, dus voorverwarmen is vereist. Het meest geschikt voor items die langzaam koken vereisen.</p>
 <p>Alleen boven- en onder element: een traditionele kookmethode die het meest geschikt is voor losse items in het midden van de oven. de bovenkant van de oven zal altijd het heetst zijn. Ideaal voor gebraden vlees, fruitcake, brood etc.</p>	 <p>Circulaire: De combinatie van de ventilator en het ronde element eromheen zorgt voor een hete lucht kookmethode. Dit biedt vele voordelen, waaronder geen voorverwarmen als de kooktijd meer dan 20 minuten bedraagt, geen smaakoverdracht bij het gelijktijdig bereiden van verschillende soorten voedsel, minder energie en kortere kooktijden. Geschikt voor alle soorten voedsel.</p>
 <p>De combinatie van de grill, de ventilator en onderwarmte is interessant voor het bereiden van kleine hoeveelheden.</p>	 <p>Grill element: Using of grill gives excellent results when cooking meat of medium and small portions, especially when combined with a rotisserie (where possible). Also ideal for cooking sausages and bacon.</p>

-  Light
-  Induction: The work of these hobs is based on the principle of electromagnetic induction. The heat is generated directly in the bottom of the pan during its contact with the hob.
-  All glass inner door: All glass inner door, a single flat surface which is simple to keep clean.
-  Side lights: Two opposing side lights increase visibility inside the oven.
-  Plate rack warming: function for heating or keeping dishes warm. Place the baking tray on the lowest shelf and stack the dishes to be heated.
-  The oven cavity has 2 different cooking levels.
-  The oven cavity has 4 different cooking levels.
-  The oven cavity has 9 different cooking levels.
-  Telescopic rails: allow you to pull out the dish and check it without having to remove it from the oven entirely.
-  Electronic control: Allows you to maintain temperature inside the oven with the precision 2-3 ° C. This enables to cook meals that are very sensitive to temperature changes, such as cakes, souffles, puddings.
-  Tilting grill: the tilting grill can be easily unhooked to move the heating element and clean the roof of the appliance in one simple step.
-  Vapor Clean: a simple cleaning function using steam to loosen deposits in the oven cavity.
-  The capacity indicates the amount of usable space in the oven cavity in litres.
-  The capacity indicates the amount of usable space in the oven cavity in litres.
-  The capacity indicates the amount of usable space in the oven cavity in litres.
-  Knobs control



## Benefit (TT)

---

### **Induction hob**

Induction offers fast cooking and precise temperature control

Through the use of suitable cookware, induction is easy to use and maintain, safe and responsive.

### **Vapor Clean**

By inserting water into a recess at the bottom of the cavity, steam is generated, which softens the residue and facilitates its removal

By inserting water into a recess at the bottom of the cavity, steam is generated, which softens the residue and facilitates its removal.

### **Buttons control**

Easy and intuitive timer setting with a simple buttons

### **True-convection**

The best cooking performances guaranteed by ventilated circular flow

Multiple fans and heating elements guarantee the perfect aerodynamic heat flow, allowing homogeneous and quicker cooking inside the cavity.

### **Multilevel cooking**

Several cooking levels allow maximum flexibility of use

### **Multilevel halogen light**

Internal halogen lighting on different levels guarantees excellent visibility

### **Tangential cooling**

New cooling system with tangential fan and airflow from the door to the splashback

### **Telescopic guides**

Easy extraction and safe insertion of trays into the oven thanks to telescopic guides

### **Isothermic Cavity**

The best cooking performance at the highest energy efficiency

### **Adjustable height**

Cooker top flushed with the working area thanks to adjustable feet

### **BBQ (optional accessory)**

Barbeque cooking directly in the oven with the double-sided grill (BBQ optional accessory)

---

**Pizza stone (optional accessory)**

Baking with refractory stone for soft and crispy pizza and yeast products (STONE optional accessory)

**Cold door**

During any function, the external door glass is cold, avoiding any risk of burns

**AirFry (AIRFRY optional accessory)**

Lighter and tastier food thanks to airfry basket (optional accessory)

**Single turbine**

The oven has a fan equipped with a circular heating element allowing cooking with rotating heat