

TR4110BL1

Categorie fornuis	110x60 cm
N. of cavities with energy label	2
Cavity heat source	Elektriciteit
Type kookplaat	Gas
Type primaire oven	Thermogeventileerd
Type secundaire oven	Geventileerd
Reinigingssysteem primaire oven	Vapor Clean reiniging
EAN-code	8017709176648
Energie-efficiëntieklasse	A
Energie-efficiëntieklasse, tweede oven	A



Design



Design	Victoria	Bedieningsknoppen	Smeg Victoria
Design	Victoria	Kleur	Inox
Kleur	Zwart	bedieningsknoppen	
Afwerking	Glanzend	Aantal	12
Afwerking	Gekleurd plaatstaal	bedieningsknoppen	
bedieningspaneel		Kleur serigrafie	Zilver
Logo	assembled 50's	Display	Elektronisch 5 toetsen
Positie logo	Upstand	Deur	Met kader
Upstand	Ja	Type glas	Zwart
Kleur kookplaat	Black enamel	Handgreep	Smeg Victoria
Type pottendragers	Gietijzeren pottendragers	Kleur handgreep	Geborsteld inox
Bediening	Bedieningsknoppen	Opbergruimte	Opbergvak met lade
		Plint	Antraciet

Programma's / Functies

Aantal kookfuncties	5
Traditionele bereidingsfuncties	



Statisch



Geventileerd



Circulatie (ventilator + circulaire)



ECO

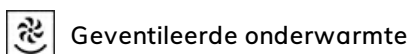

Geventileerde onderwarmte

Overige functies

 Ontdooien

Reinigingsfuncties

 Vapor Clean reiniging

Programma's / Functies secundaire oven

Aantal kookfuncties 5

Traditionele bereidingsfuncties, 2e oven

 Statisch

 Geventileerd

 Ventilator + grote grill

 Onderwarmte

 Geventileerde onderwarmte

Vapor Clean reiniging



Reinigingsfunctie 2e oven

Overige functies 2e oven

 Ontdooien

Programma's / Functies derde oven

Aantal functies derde oven

1

Licht



Grote vlakgrill



Technische specificaties kookplaat

UR

Totaal aantal kookzones 7

Linksvoor - Gas - 2URP (dual) - 4.20 kW

Linksvoor - Gas - AUX - 1.00 kW

Linksachter - Gas - RP - 2.90 kW

Middenvoor - Gas - RP - 2.90 kW

Middenachter - Gas - AUX - 1.00 kW

Rechtsvoor - Gas - SRD - 1.80 kW

Rechtsachter - Gas - SRD - 1.80 kW

Type gasbranders Standaard

Thermobeveiliging

Ja

Automatische vonkontsteking Ja

Branderdeksels

Mat zwart geëmailleerd

Technische specificaties primaire oven



Aantal lampen	1
Netto volume 1e oven	61 l
Bruto volume, oven 1	70 l
Materiaal ovenruimte	Ever Clean emaille
Aantal kookniveaus	4
Type ovenrekken	Metalen zijsteunen
Type licht	Halogeen
Vermogen lamp	40 W
Opties bereidingstijdprogrammering	Begin en eind
Opening deur	Side opening
Uitneembare ovendeur	Ja
Volledig glazen binnendeur	Ja
Uitneembaar glas binnendeur	Ja

Aantal ruiten ovendeur	3
Aantal thermo-reflecterende ruiten	1
Veiligheidsthermostaat	Ja
Koelsysteem	Mantelkoeling
Afmetingen bruikbare interne ovenruimte (hxbxd)	316x460x412 mm
Temperatuurregeling	Elektro-mechanisch
Onderwarmte - vermogen	1200 W
Bovenwarmte - vermogen	1000 W
Grill - vermogen	1700 W
Grote vlakgrill - vermogen	2700 W
Circulatie - vermogen	2700 W
Grill type	Elektrisch

Opties primaire oven

Timer	Ja	Minimum temperatuur	50 °C
Geluidssignaal einde kooktijd	Ja	Maximum temperatuur	260 °C

Technische specificaties secundaire oven



Netto volume 2e oven	61 l
Bruto volume, oven 2	70 l
Materiaal ovenruimte	Ever Clean emaille
Aantal kookniveaus	4
Type ovenrekken	Metalen zijsteunen
Aantal lampen	1
Type lamp	Halogeen
Vermogen lamp	40 W
Opening deur	Side opening
Uitneembare ovendeur	Ja
Volledig glazen binnendeur	Ja
Uitneembaar glas binnendeur	Ja

Aantal ruiten ovendeur	3
Aantal thermo-reflecterende ruiten	1
Veiligheidsthermostaat	Ja
Koelsysteem	Mantelkoeling
Afmetingen bruikbare interne ovenruimte (hxbxd)	316x444x425 mm
Temperatuurregeling	Elektro-mechanisch
Onderwarmte - vermogen	1200 W
Bovenwarmte - vermogen	1000 W
Grill - vermogen	1700 W
Grote vlakgrill - vermogen	2700 W
Type grill	Elektrisch
Kantelbare grill	Ja

Opties secundaire oven

Minimum temperatuur 50 °C

Maximum temperatuur 260 °C

Technische specificaties derde oven



Netto volume, 3e oven	36 l	Uitneembaar glas binnendeur	Ja
Bruto volume, oven 3	41 l	Aantal ruiten ovendeur	3
Materiaal ovenruimte	Ever Clean emaille	Aantal thermo-reflecterende ruiten	1
Aantal kookniveaus	2	Veiligheidsthermostaat	Ja
Type ovenrekken	Metalen zijsteunen	Koelsysteem	Mantelkoeling
Aantal lampen	1	Afmetingen bruikbare interne ovenruimte (hxbxd)	169x440x443 mm
Type lamp	Gloeilamp	Temperatuurregeling	Elektro-mechanisch
Vermogen lamp	25 W	Grote vlakgrill - vermogen	2700 W
Opening deur	Neerwaarts	Type grill	Elektrisch
Uitneembare ovendeur	Ja	Kantelbare grill	Ja
Volledig glazen binnendeur	Ja		

Opties derde oven

Minimum temperatuur 50 °C

Maximum temperatuur 260 °C

Meegeleverde accessoires primaire oven en kookplaat



Gietijzeren wokring	1	Inzetrooster	1
Ovenrooster met stop	2	Telescopische geleiders, gedeeltelijk uitschuifbaar	1
Bakplaat (40 mm)	1		

Meegeleverde accessoires secundaire oven



Ovenrooster met stop	2	Inzetrooster	1
Bakplaat (40 mm)	1	Telescopische geleiders, gedeeltelijk uitschuifbaar	1

Meegeleverde accessoires derde oven

Ovenrooster met stop	1	Bakplaat (40 mm)	1
-----------------------------	---	-------------------------	---

Elektrische aansluiting

Nominale aansluitwaarde	8400 W	Testkabel	Ja
Stroom	37 A	Type stroomkabel	Double and Three Phase
Spanning	220-240 V	Frequentie	50/60 Hz
Spanning 2 (V)	380-415 V	Connection box	5 polig
Electric cable	Installed, Single phase		

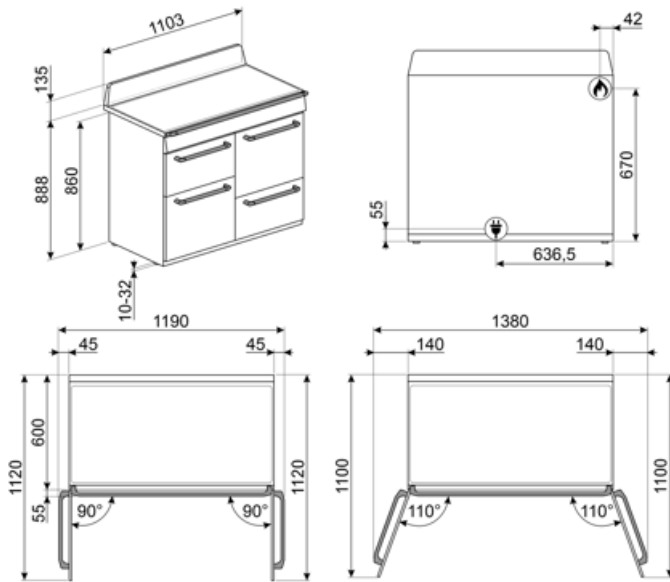

Compatible Accessories

AIRFRY



BGTR4110

Cast iron grill plate suitable for Victoria Cookers TR4110



BN640

Enamelled tray suitable for 45cm and 60cm ovens. Depth 540 mm. Perfect for cooking and roasting meat and fish in sauces. Also ideal for experimenting with lighter and crunchy side dishes



GTP

Partially extractable telescopic guides (1 level), suitable for traditional ovens. Made in stainless steel, they guarantee stability and facilitate the smooth extraction of the trays.



KIT1TR41N

Splashback black, 110cm, suitable for TR4110 Victoria cookers



KITH4110

Height extension kit (950mm), black, suitable for TR4110 cookers (945-965mm)



PALPZ

Pizzapallet inox met plooibaar handvat, 315x325 mm



SMOLD

Set van 7 siliconen vormen voor ijsjes, pralines, ijsblokjes of porties. -60°C tot 230°C.

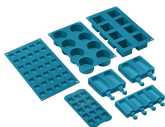

BBQ

Dubbelzijdig



BN620-1

Enamelled tray suitable for 45cm and 60cm ovens. Depth 20 mm. Perfect for a wide range of savoury and sweet baking.



BNP608T

Teflon bakplaat, 8mm diep



GTT

Volledig uitschuifbare telescopische rails (1 niveau) voor traditionele ovens (SF-).



KIT600TR4110

Cover strip for hob back side, suitable for TR4110 Victoria cookers



KITP65TR41

Depth extension kit (650 mm), black, suitable for TR4110 cookers



SFLK1

Child lock































TPKTR

Stainless steel teppanyaki plate, suitable for Victoria TR4110 cookers and Symphony SYD4110



Symbols glossary

	 <p>Heavy duty cast iron pan stands: for maximum stability and strength.</p>
 <p>Installation in column: Installation in column</p>	 <p>Air cooling system: to ensure a safe surface temperatures.</p>
 <p>With the switch on this symbol, no heating is possible even if the thermostat is turned.</p>	 <p>Triple glazed doors: Number of glazed doors.</p>
 <p>Ever Clean Enamel: Ever Clean enamel is applied electrostatically, corner to corner and edge to edge to prevent cracking or cracks over time. It is a particular pyrolytic enamel, resistant to acids which, in addition to being pleasantly bright, promotes greater cleaning of the oven walls, thanks to its lower porosity. It is baked at over 850 ° C and slowly polymerized at a scientifically determined rate to ensure uniform depth and strength Ever Clean enamel creates an impeccable finish both on the inside of the oven and on the trays, making the surfaces of the oven incredibly easy to maintain over time as it reduces the adhesion of fat during cooking</p>	 <p>Circogas: In gasovens verdeelt de ventilator de warmte snel en gelijkmatig over de ovenruimte, waardoor smaakoverdracht wordt vermeden bij het tegelijkertijd bereiden van een aantal verschillende gerechten. In elektrische ovens voltooit deze combinatie het koken van voedsel dat aan de oppervlakte klaar is, maar dat van binnen meer moet worden gekookt, zonder verder bruin te worden.</p>
 <p>Ventilator met bovenste en onderste elementen: De elementen in combinatie met de ventilator zijn bedoeld om een meer gelijkmatige warmte te bieden, een methode die vergelijkbaar is met conventioneel koken, dus voorverwarmen is vereist. Het meest geschikt voor items die langzaam koken vereisen.</p>	 <p>Alleen boven- en onder element: een traditionele kookmethode die het meest geschikt is voor losse items in het midden van de oven. de bovenkant van de oven zal altijd het heetst zijn. Ideaal voor gebraden vlees, fruitcake, brood etc.</p>
 <p>Base: the heat comes only from the bottom of the cavity. The fan is not active. Ideal for sweet and savory pies, cobblers and pizzas. Designed to complete cooking and make food more crunchy This symbol in gas ovens indicates the gas burner.</p>	 <p>Circulaire: De combinatie van de ventilator en het ronde element eromheen zorgt voor een hete lucht kookmethode. Dit biedt vele voordelen, waaronder geen voorverwarmen als de kooktijd meer dan 20 minuten bedraagt, geen smaakoverdracht bij het gelijktijdig bereiden van verschillende soorten voedsel, minder energie en kortere kooktijden. Geschikt voor alle soorten voedsel.</p>
 <p>De combinatie van de grill, de ventilator en onderwarmte is interessant voor het bereiden van kleine hoeveelheden.</p>	 <p>Grill element: Using of grill gives excellent results when cooking meat of medium and small portions, especially when combined with a rotisserie (where possible). Also ideal for cooking sausages and bacon.</p>
 <p>Fan grill: very intense heat coming only from above from a double heating element The fan is active. It allows the optimal grilling of thickest meats. Ideal for large cuts of meat.</p>	 <p>Light</p>
 <p>All glass inner door: All glass inner door, a single flat surface which is simple to keep clean.</p>	 <p>The inner door glass: can be removed with a few quick movements for cleaning.</p>

-
-  Side lights: Two opposing side lights increase visibility inside the oven.
 -  The oven cavity has 4 different cooking levels.
 -  Electronic control: Allows you to maintain temperature inside the oven with the precision 2-3 ° C. This enables to cook meals that are very sensitive to temperature changes, such as cakes, souffles, puddings.
 -  Ultra rapid burners: Powerful ultra rapid burners offer up to 5kw of power.
 -  The capacity indicates the amount of usable space in the oven cavity in litres.
 -  Knobs control
 -  The oven cavity has 2 different cooking levels.
 -  Telescopic rails: allow you to pull out the dish and check it without having to remove it from the oven entirely.
 -  Tilting grill: the tilting grill can be easily unhooked to move the heating element and clean the roof of the appliance in one simple step.
 -  Vapor Clean: a simple cleaning function using steam to loosen deposits in the oven cavity.
 -  The capacity indicates the amount of usable space in the oven cavity in litres.

Benefit (TT)

Gas hob

Gas provides permanent control of the heat source and the temperature change is immediate

Equipped with a thermocouple, the gas supply is cut off if the flame is extinguished for greater safety.

Vapor Clean

By inserting water into a recess at the bottom of the cavity, steam is generated, which softens the residue and facilitates its removal

By inserting water into a recess at the bottom of the cavity, steam is generated, which softens the residue and facilitates its removal.

Buttons control

Easy and intuitive timer setting with a simple buttons

Drawer storage compartment

More space thanks to the lower drawer compartment, ideal for storing accessories or cooking utensils

True-convection

The best cooking performances guaranteed by ventilated circular flow

Multiple fans and heating elements guarantee the perfect aerodynamic heat flow, allowing homogeneous and quicker cooking inside the cavity.

Multilevel cooking

Several cooking levels allow maximum flexibility of use

Multilevel halogen light

Internal halogen lighting on different levels guarantees excellent visibility

Removable inner glass

Internal door glasses are easily removable for complete cleaning

Tangential cooling

New cooling system with tangential fan and airflow from the door to the splashback

Telescopic guides

Easy extraction and safe insertion of trays into the oven thanks to telescopic guides

Isothermic Cavity

The best cooking performance at the highest energy efficiency

BBQ (optional accessory)

Barbeque cooking directly in the oven with the double-sided grill (BBQ optional accessory)

Pizza stone (optional accessory)

Baking with refractory stone for soft and crispy pizza and yeast products (STONE optional accessory)

Adjustable height

Cooker top flushed with the working area thanks to adjustable feet

Cold door

During any function, the external door glass is cold, avoiding any risk of burns

AirFry (AIRFRY optional accessory)

Lighter and tastier food thanks to airfry basket (optional accessory)