

## TR62IBL2

Categorie fornuis	60x60 cm
N. of cavities with energy label	2
Cavity heat source	Elektriciteit
Type kookplaat	Inductie
Type primaire oven	Thermogeventileerd
Type secundaire oven	Statisch
EAN-code	8017709309541
Energie-efficiëntieklasse	A
Energie-efficiëntieklasse, tweede oven	A







## Design

			
<b>Design</b>	Victoria	<b>Bedieningsknoppen</b>	Smeg Victoria
<b>Afwerking bedieningspaneel</b>	Gekleurd plaatstaal	<b>Kleur bedieningsknoppen</b>	Inox
<b>Design</b>	Victoria	<b>Aantal bedieningsknoppen</b>	6
<b>Logo</b>	assembled 50's	<b>Kleur serigrafie</b>	Zilver
<b>Kleur</b>	Zwart	<b>Display</b>	Elektronisch 5 toetsen
<b>Positie logo</b>	Upstand	<b>Deur</b>	Met kader
<b>Afwerking</b>	Glanzend	<b>Type glas</b>	Zwart
<b>Upstand</b>	Ja	<b>Handgreep</b>	Smeg Victoria
<b>Kleur kookplaat</b>	Black enamel	<b>Kleur handgreep</b>	Geborsteld inox
<b>Bediening</b>	Bedieningsknoppen	<b>Plint</b>	Antraciet

## Programma's / Functies

<b>Aantal kookfuncties</b>	4
<b>Traditionele bereidingsfuncties</b>	

 Statisch	 Kleine grill	 Grote grill
 Onderwarmte		

## Technische specificaties kookplaat

**Totaal aantal kookzones 4**

Linksvoor - Inductie - enkel - 2.30 kW - Booster 3.00 kW - - Ø 21.0 cm

Linksachter - Inductie - enkel - 1.20 kW - Booster 1.40 kW - - Ø 16.0 cm

Rechtsachter - Inductie - maxi - 2.30 kW - Booster 3.00 kW - - Ø 21.0 cm

Rechtsvoor - Inductie - enkel - 1.20 kW - Booster 1.40 kW - - Ø 16.0 cm

<b>Aantal kookzones met booster</b>	4	<b>Indicator minimaal te gebruiken diameter</b>	Ja
<b>Automatisch uitschakelen i.g.v. oververhitting</b>	Ja	<b>Indicator geselecteerde zone</b>	Ja
<b>Automatische aanpassing panafmeting</b>	Ja	<b>Indicator (lampje) restwarmte</b>	Ja

## Technische specificaties primaire oven



<b>Aantal lampen</b>	1	<b>Uitneembare ovendeur</b>	Ja
<b>Aantal ventilatoren</b>	1	<b>Volledig glazen binnendeur</b>	Ja
<b>Netto volume 1e oven</b>	61 l	<b>Uitneembaar glas binnendeur</b>	Ja
<b>Bruto volume, oven 1</b>	70 l	<b>Aantal ruiten ovendeur</b>	3
<b>Materiaal ovenruimte</b>	Ever Clean emaille	<b>Aantal thermo-reflecterende ruiten</b>	1
<b>Aantal kookniveaus</b>	4	<b>Veiligheidsthermostaat</b>	Ja
<b>Type ovenrekken</b>	Metalen zijsteunen	<b>Koelsysteem</b>	Mantelkoeling
<b>Type licht</b>	Halogeen	<b>Afmetingen bruikbare interne ovenruimte (hxbxd)</b>	316x460x412 mm
<b>Vermogen lamp</b>	40 W	<b>Temperatuurregeling</b>	Elektro-mechanisch
<b>Opties bereidingstijdprogrammering</b>	Begin en eind	<b>Circulatie - vermogen</b>	2700 W
<b>Opening deur</b>	Neerwaarts		

## Opties primaire oven

<b>Timer</b>	Ja	<b>Minimum temperatuur</b>	50 °C
<b>Geluidssignaal einde kooktijd</b>	Ja	<b>Maximum temperatuur</b>	245 °C

## Technische specificaties secundaire oven



<b>Netto volume 2e oven</b>	35 l	<b>Aantal ruiten ovendeur</b>	3
<b>Bruto volume, oven 2</b>	41 l	<b>Aantal thermo-reflecterende ruiten</b>	1
<b>Materiaal ovenruimte</b>	Ever Clean emaille	<b>Veiligheidsthermostaat</b>	Ja
<b>Aantal kookniveaus</b>	2	<b>Koelsysteem</b>	Mantelkoeling
<b>Type ovenrekken</b>	Metalen zijsteunen		
<b>Aantal lampen</b>	1		

Type lamp	Halogeen	Afmetingen bruikbare interne ovenruimte (hxbxd)	169x440x443 mm
Vermogen lamp	40 W	Temperatuurregeling	Elektro-mechanisch
Opening deur	Neerwaarts	Onderwarmte - vermogen	1200 W
Uitneembare ovendeur	Ja	Bovenwarmte - vermogen	1000 W
Volledig glazen binnendeur	Ja	Grill - vermogen	1700 W
Uitneembaar glas binnendeur	Ja	Grote vlakgrill - vermogen	2700 W
		Type grill	Elektrisch
		Kantelbare grill	Ja

## Opties secundaire oven

Minimum temperatuur	50 °C	Maximum temperatuur	245 °C
---------------------	-------	---------------------	--------

## Meegeleverde accessoires primaire oven en kookplaat



Ovenrooster met stop	2	Inzetrooster	1
Bakplaat (40 mm)	1	Telescopische geleiders, volledig uitschuifbaar	1

## Meegeleverde accessoires secundaire oven

Ovenrooster met stop	1	Inzetrooster	1
Bakplaat (40 mm)	1		

## Elektrische aansluiting

Nominale aansluitwaarde	12700 W	Type stroomkabel	Double and Three Phase
Stroom	38 A	Frequentie	50/60 Hz
Spanning	220-240 V	Connection box	5 polig
Spanning 2 (V)	380-415 V	Stekker	Nee
Electric cable	Installed, Single phase		

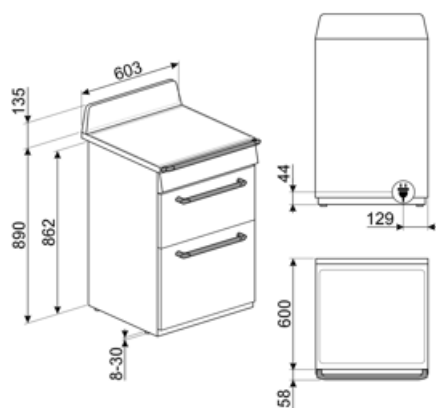

## Compatible Accessories

### AIRFRY



### BBQ

Dubbelzijdig



### BN640

Enamelled tray suitable for 45cm and 60cm ovens. Depth 540 mm. Perfect for cooking and roasting meat and fish in sauces. Also ideal for experimenting with lighter and crunchy side dishes

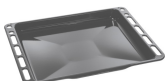

### GRILLPLATE

Universal griddle for induction, gas, ceramic and electric hobs. Non-stick surface ideal for cooking meat, cheese and vegetables. Dimensions: 410 x 240 mm.



### GTT

Volledig uitschuifbare telescopische rails (1 niveau) voor traditionele ovens (SF-).



### KITH60

Height extension kit (950 mm), black, suitable for TR60 cookers



### SCRP

Schraper voor inductie- en vitrokeramische kookplaten



### SMOLD

Set van 7 siliconen vormen voor ijsjes, pralines, ijsblokjes of porties. -60°C tot 230°C.

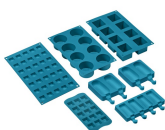

### AIRFRY2

Air fryer tray. Ideal for recreating traditional frying in the oven, but with fewer calories and less fat. It allows you to cook quickly and simply dishes such as French fries, fried vegetables and fish, ensuring perfect browning and crispiness.



### BN620-1

Enamelled tray suitable for 45 cm and 60 cm ovens. Depth 20 mm. Perfect for a wide range of savoury and sweet baking.



### BNP608T

Teflon bakplaat, 8mm diep



### GTP

Partially extractable telescopic guides (1 level), suitable for traditional ovens. Made in stainless steel, they guarantee stability and facilitate the smooth extraction of the trays.



### KIT1TR6N

Splashback black, 60cm ,suitable for TR62 Victoria cookers



### PALPZ

Pizzapallet inox met plooibaar handvat, 315x325 mm



### SFLK1

Child lock



### STONE

Rectangular refractory stone Ideal for cooking pizzas with the same results as a typical wood-fired oven. Can also be used for baking bread, focaccias and other recipes such as pies, flans or biscuits Dimensions:L42 x H1,8 x P37,5 cm.

































### TPKPLATE



Universal plate for induction, gas, ceramic and electric hobs. Non-stick surface ideal for cooking fish, eggs and vegetables. Dimensions: 410 X 240 mm.

## Symbols glossary

 Energy efficiency class A	 Power booster: option allows the zone to work at full power when very intense cooking is necessary.
 Sommige modellen zijn voorzien van een functie om het programma/de cyclus te blokkeren zodat het niet per ongeluk kan aangepast worden.	 Installation in column: Installation in column.
 Air cooling system: to ensure a safe surface temperatures.	 Triple glazed doors: Number of glazed doors.
 ECO-logic: option allows you to restrict the power limit of the appliance real energy saving.	 Ever Clean Enamel: Ever Clean enamel is applied electrostatically, corner to corner and edge to edge to prevent cracking or cracks over time. It is a particular pyrolytic enamel, resistant to acids which, in addition to being pleasantly bright, promotes greater cleaning of the oven walls, thanks to its lower porosity. It is baked at over 850 °C and slowly polymerized at a scientifically determined rate to ensure uniform depth and strength. Ever Clean enamel creates an impeccable finish both on the inside of the oven and on the trays, making the surfaces of the oven incredibly easy to maintain over time as it reduces the adhesion of fat during cooking.
 Alleen boven- en onder element: een traditionele kookmethode die het meest geschikt is voor losse items in het midden van de oven. de bovenkant van de oven zal altijd het heetst zijn. Ideaal voor gebraden vlees, fruitcake, brood etc.	 Base: the heat comes only from the bottom of the cavity. The fan is not active. Ideal for sweet and savory pies, cobblers and pizzas. Designed to complete cooking and make food more crunchy. This symbol in gas ovens indicates the gas burner.
 Circulaire: De combinatie van de ventilator en het ronde element eromheen zorgt voor een hete lucht kookmethode. Dit biedt vele voordelen, waaronder geen voorverwarmen als de kooktijd meer dan 20 minuten bedraagt, geen smaakoverdracht bij het gelijktijdig bereiden van verschillende soorten voedsel, minder energie en kortere kooktijden. Geschikt voor alle soorten voedsel.	 Grill: Very intense heat coming only from above from a double heating element. The fan is not active. Provides excellent grilling and gratinating results. Used at the end of cooking, it gives a uniform browning to dishes.
 Half grill: For rapid cooking and browning of foods. Best results can be obtained by using the top shelf for small items, the lower shelves for larger ones, such as chops or sausages. For half grill heat is generated only at the centre of the element, so is ideal for smaller quantities.	 Light
 Giant zone: The giant zone offers extra space and flexibility.	 Overheat protection: The safety system that automatically turns off the hob in case of overheating of the control unit.

- 
- |  |   |   |   |
|--|---|---|---|
|    | Induction: The work of these hobs is based on the principle of electromagnetic induction. The heat is generated directly in the bottom of the pan during its contact with the hob.  |    | All glass inner door: All glass inner door, a single flat surface which is simple to keep clean.  |
|    | The inner door glass: can be removed with a few quick movements for cleaning.   |    | Side lights: Two opposing side lights increase visibility inside the oven.  |
|    | Automatic opening: some models have Automatic opening door when the cycle is finished which is a perfect solution for handle-less kitchen units as no handle is needed. For safety reasons, the door locks automatically when the machine is in use to avoid it being opened inadvertently. |    | Indication of residual heat: After the glass ceramic hob is switched off the residual heat indicator shows which of the heating zones still remains hot. When the temperature drops below 60 ° C, the indicator goes out. |
|    | The oven cavity has 2 different cooking levels.   |    | The oven cavity has 4 different cooking levels.   |
|    | Telescopic rails: allow you to pull out the dish and check it without having to remove it from the oven entirely.   |    | Electronic control: Allows you to maintain temperature inside the oven with the precision 2-3 ° C. This enables to cook meals that are very sensitive to temperature changes, such as cakes, souffles, puddings.          |
|   | Tilting grill: the tilting grill can be easily unhooked to move the heating element and clean the roof of the appliance in one simple step.   |   | The capacity indicates the amount of usable space in the oven cavity in litres.   |
|  | The capacity indicates the amount of usable space in the oven cavity in litres.   |  | Knobs control   |



## Benefit (TT)

---

### **Induction hob**

Induction offers fast cooking and precise temperature control

Through the use of suitable cookware, induction is easy to use and maintain, safe and responsive.

### **Ever Clean Enamel**

Easy oven cleaning thanks to special pyrolytic enamel

### **Buttons control**

Easy and intuitive timer setting with a simple buttons

### **True-convection**

The best cooking performances guaranteed by ventilated circular flow

Multiple fans and heating elements guarantee the perfect aerodynamic heat flow, allowing homogeneous and quicker cooking inside the cavity.

### **Multilevel cooking**

Several cooking levels allow maximum flexibility of use

### **Multilevel halogen light**

Internal halogen lighting on different levels guarantees excellent visibility

### **Removable inner glass**

Internal door glasses are easily removable for complete cleaning

### **Tangential cooling**

New cooling system with tangential fan and airflow from the door to the splashback

### **Telescopic guides**

Easy extraction and safe insertion of trays into the oven thanks to telescopic guides

### **Isothermic Cavity**

The best cooking performance at the highest energy efficiency

### **Cold door**

During any function, the external door glass is cold, avoiding any risk of burns

### **AirFry (AIRFRY optional accessory)**

Lighter and tastier food thanks to airfry basket (optional accessory)

**Pizza stone (optional accessory)**

Baking with refractory stone for soft and crispy pizza and yeast products (STONE optional accessory)

**BBQ (optional accessory)**

Barbecue cooking directly in the oven with the double-sided grill (BBQ optional accessory)

**Adjustable height**

Cooker top flushed with the working area thanks to adjustable feet

**Single turbine**

The oven has a fan equipped with a circular heating element allowing cooking with rotating heat