

# TR93BLD

Categorie fornuis	90x60 cm
Aantal ovens met energielabel	2
Cavity heat source	Elektrisch
Type kookplaat	Gas
Type primaire oven	Thermogeventileerd
Type secundaire oven	Thermogeventileerd
Reinigingssysteem primaire oven	Vapor Clean
EAN-code	8017709209452
Energie-efficiëntieklasse	A
Energie-efficiëntieklasse, tweede oven	B



## Design











Esthetiek	Victoria	Bedieningsknoppen	Smeg Victoria
Design	Victoria	Kleur knoppen	Roestvrij staal
Kleur	Zwart	Aantal bedieningsknoppen	10
Afwerking bedieningspaneel	Gekleurd plaatstaal	Kleur serigrafie	Zilver
Logo	assembled 50's	Display	Elektronisch 5 toetsen
Positie logo	Upstand+ Bedieningspaneel	Deur	Met kader
Upstand	Ja	Type glas	Zwart
Kleur kookplaat	Zwart glanzend	Handgreep	Smeg Victoria
Type pannendragers	Gietijzer	Kleur handgreep	Geborsteld roestvrijstaal
Type bediening	Bedieningsknoppen	Plint	Antraciet

## Programma's / functies

Aantal kookfuncties 8

Traditionele kookfuncties

 Statisch	 Circulaire	 Turbo
 ECO	 Kleine grill	 Grote vlak-grill
 Fan grill (large)	 Fan assisted base	

## Overige functies

 Ontdooien op tijd

## Schoonmaak functie

 Vapor Clean

## Programma's / functies secundaire oven

Kookfuncties ovenruimte 2 1

Traditionele kookfuncties, ovenruimte 2

 Circulaire

## Programma's / functies derde oven

Aantal functies derde oven 1

Licht 

Grote vlakgrill 

## Technische specificaties kookplaat

**UR**

**Totaal aantal kookzones** 6

Linksvoor - Gas - 2URP (dual) - 4.20 kW

Linksachter - Gas - AUX - 1.00 kW

Middenvoor - Gas - AUX - 1.00 kW

Middenachter - Gas - SRD - 1.80 kW

Rechtsvoor - Gas - SRD - 1.80 kW

Rechtsachter - Gas - RP - 2.90 kW

Type gasbranders Standaard

Thermobeveiliging

Ja

Automatische vonkontsteking Ja

Branderdeksels

Mat zwart geëmailleerd

## Technische specificaties primaire oven



Aantal lampen 1

Aantal ventilatoren 1

Netto inhoud 61 l

Bruto inhoud 1e oven 70 l

Materiaal ovenruimte Ever Clean emaille

Aantal kookniveaus 4

Type ovenrekken Metalen zijsteunen

Soort verlichting Halogeen

Aantal ruiten ovendeur 3

Aantal thermo-

reflecterende ruiten 1

Veiligheidsthermostaat Ja

Koelsysteem Mantelkoeling

Afmetingen bruikbare interne ovenruimte (hxbxd) 316x444x425 mm

Vermogen lamp	40 W	Temperatuurregeling	Elektro-mechanisch
Instelling kooktijd	Start en stop	Onderwarmte - vermogen	1200 W
Deur openen	Side opening	Bovenwarmte - vermogen	1000 W
Uitneembare ovendeur	Ja	Grill - vermogen	1700 W
Volledig glazen binnendeur	Ja	Grote vlakgrill - vermogen	2700 W
Uitneembaar glas binnendeur	Ja	Circulatie - vermogen	2000 W
		Type grill	Elektrisch
		Kantelbare grill	Ja

## Opties primaire oven

Timer	Ja	Minimum temperatuur	50 °C
Akoestisch signaal einde kooktijd	Ja	Maximum temperatuur	260 °C

## Technische specificaties secundaire oven



Netto inhoud (l) oven 2	62 l	Volledig glazen binnendeur	Ja
Bruto inhoud, 2e oven	69 l	Uitneembaar glas binnendeur	Ja
Materiaal ovenruimte	Ever Clean emaille	Aantal ruiten ovendeur	2
Aantal kookniveaus	9	Aantal thermo-reflecterende ruiten	1
Type ovenrekken	Metalen zijsteunen	Veiligheidsthermostaat	Ja
Aantal lampen	1	Koelsysteem	Mantelkoeling
Soort verlichting	Halogeen	Afmetingen bruikbare interne ovenruimte (hxbxd)	605x275x370 mm
Vermogen lamp	40 W	Temperatuurregeling	Elektro-mechanisch
Deur openen	Side opening	Circulatie - vermogen	2500 W
Uitneembare ovendeur	Ja		

## Opties secundaire oven

Minimum temperatuur	50 °C	Maximum temperatuur	245 °C
---------------------	-------	---------------------	--------

## Technische specificaties derde oven



Netto inhoud (l) oven 3	35 l	Uitneembaar glas binnendeur	Ja
Bruto inhoud, 3e oven	41 l	Aantal ruiten ovendeur	3
Materiaal ovenruimte	Ever Clean emaille	Aantal thermo-reflecterende ruiten	1
Aantal kookniveaus	2		
Type ovenrekken	Metalen zijsteunen		

<b>Aantal lampen</b>	1	<b>Veiligheidsthermostaat</b>	Ja
<b>Soort verlichting</b>	Halogeen	<b>Koelsysteem</b>	Mantelkoeling
<b>Vermogen lamp</b>	40 W	<b>Afmetingen bruikbare interne ovenruimte (hxbxd)</b>	169x440x443 mm
<b>Deur openen</b>	naar beneden	<b>Temperatuurregeling</b>	Elektro-mechanisch
<b>Uitneembare ovendeur</b>	Ja	<b>Grote vlakgrill - vermogen</b>	2700 W
<b>Volledig glazen binnendeur</b>	Ja	<b>Type grill</b>	Elektrisch
		<b>Kantelbare grill</b>	Ja

## Opties derde oven

<b>Minimum temperatuur</b>	50 °C	<b>Maximum temperatuur</b>	260 °C
----------------------------	-------	----------------------------	--------

## Meegeleverde accessoires primaire oven en kookplaat



<b>Gietijzeren wokring</b>	1	<b>Bakplaat (40 mm)</b>	1
<b>Gietijzeren houder t.b.v. caffettiera</b>	1	<b>Inzetrooster</b>	1
<b>Ovenrooster met stop</b>	2	<b>Telescopische geleiders, gedeeltelijk uitschuifbaar</b>	1

## Meegeleverde accessoires secundaire oven



<b>Ovenrooster met stop</b>	4	<b>Bordenwarmhouder</b>	1
-----------------------------	---	-------------------------	---

## Meegeleverde accessoires derde oven

<b>Rek met achter- en zijstop</b>	1	<b>Bakplaat (40 mm)</b>	1
-----------------------------------	---	-------------------------	---

## Elektrische aansluiting

<b>Aansluitwaarde</b>	8300 W	<b>Testkabel</b>	Ja
<b>Stroom</b>	36 A	<b>Frequentie</b>	50/60 Hz
<b>Spanning</b>	220-240 V	<b>Aansluitkast</b>	5 polig
<b>Spanning 2 (V)</b>	380-415 V		

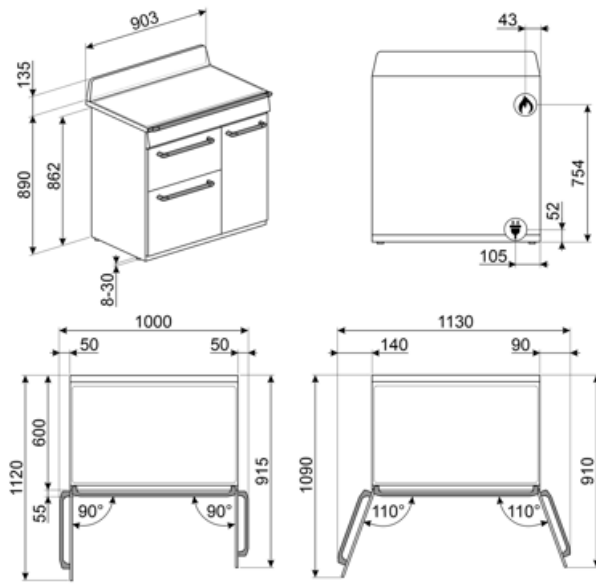

## Accessoires niet inbegrepen



### BGTR9

Gietijzeren grillplaat geschikt voor 90 cm en 100 cm Victoria



### BN640

Geëmailleerde bakplaat, 40 mm diep



### GTP

Gedeeltelijk uittrekbare telescopische geleiders (1 niveau)



### KIT1TR9N

Splashback black, 90cm ,suitable for TR90 and TR93 Victoria cookers



### KITH93

Height extension kit (950mm), black, suitable for TR93 cookers (945-960mm)

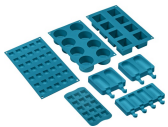

### SMOLD

Set van 7 siliconen vormpjes voor ijsjes, ijslolly's, pralines, ijsblokjes of om etenswaren te portioneren. Bruikbaar van -60 ° C tot + 230 ° C



### WOKGHU

Cast iron WOK Support



### BN620-1

Geëmailleerde bakplaat, 20 mm diep



### BNP608T

Teflon-coated tray, 8mm depth, to be placed on the grid



### GTT

Volledig uittrekbare telescopische geleiders (1 niveau)



### KIT600TR93

Cover strip for hob back side, suitable for TR93 Victoria cookers



### PALPZ

















Pizzaschep met inklapbare handgreep breedte: 315 mm lengte: 325 mm























### STONE

Rectangular refractory stone Ideal for cooking pizzas with the same results as a typical wood-fired oven. Can also be used for baking bread, focaccias and other recipes such as pies, flans or biscuits Dimensions:L42 x H1,8 x P37,5 cm.

## Symbols glossary (TT)

 <p>Heavy duty gietijzeren pannendragers: voor maximale stabiliteit en sterkte.</p>	 <p>A: Droogprestaties van het product, gemeten vanaf A +++ tot D / G afhankelijk van de productfamilie</p>
 <p>Installation in column: Installation in column</p>	 <p>Luchtkoelsysteem: om een veilig oppervlak te garanderen temperaturen.</p>
 <p>B: Energieklasse van het product, gemeten van A +++ tot D / G, afhankelijk van de productfamilie.</p>	 <p>Ontdooien op tijd: met deze functie wordt automatisch het tijdstip van ontdooien van voedsel bepaald</p>
 <p>Dubbele beglazing: aantal glazen deuren.</p>	 <p>Deuren met driedubbele beglazing: aantal glazen deuren.</p>
 <p>Geëmailleerde binnenkant: De geëmailleerde binnenkant van alle Smeg-ovens heeft een speciale antacidumvoering die helpt om de binnenkant schoon te houden door de hoeveelheid kookvet te verminderen.</p>	 <p>Fan assisted base: the mix of fan and lower heating element alone allows to finish cooking foods already cooked on the surface but not internally more quickly. This system is recommended to finish cooking foods that are already well cooked on the surface, but not internally, which therefore require a moderate higher heat. Ideal for any type of food.</p>
 <p>De ovenruimte wordt tegelijk door het onder- en bovenelement verwarmt. De hitteverdeling over het gerecht is afhankelijk van het niveau waarop men dit plaatst. Geschikt voor bakken op 1 niveau. Gerechten: alle ovenschotels, vlees, gevogelte, brood, (gevulde) taarten. Speciaal: gans en eend (bevatten veel vet).</p>	 <p>Circulaire: it is the perfect function for cooking all types of dishes in a more delicate way. The heat comes from the back of the oven and is distributed quickly and evenly The fan is active. It is also ideal for cooking on multiple levels without mixing smells and flavors.</p>
 <p>ECO: low energy consumption cooking: this function is particularly suitable for cooking on a single shelf with low energy consumption. It is recommended for all types of food except those that can generate a lot of moisture (for example vegetables). To achieve maximum energy savings and reduce time, it is recommended to put the food in the oven without preheating the cooking compartment</p>	 <p>De warmte wordt geproduceerd door het grill- en bovenelement. Verhitting over het volledige oppervlak. De thermostaat wordt, afhankelijk van het gerecht, in de regel op de maximale stand gezet. Bij een korte baktijd kan de ovendeur gesloten blijven; bij langere baktijd blijft deze gedeeltelijk geopend. Voor vleesgerechten (klein- en middelgroot), vleespennen, vis, groenten, gratineren etc.</p>
 <p>De warmte wordt geproduceerd door het grill- en bovenelement. Verhitting over het volledige oppervlak. De thermostaat wordt, afhankelijk van het gerecht, in de regel op de maximale stand gezet. Bij een korte baktijd kan de ovendeur gesloten blijven; bij langere baktijd blijft deze gedeeltelijk geopend. Voor vleesgerechten (klein- en middelgroot), vleespennen, vis, groenten, gratineren etc.</p>	 <p>De warmte is alleen afkomstig van het grill-element. Verhitting over een kleiner oppervlak. Te gebruiken als de grote vlak-grill, maar voor kleinere hoeveelheden</p>

- |  |   |
|--|---|
|  <p>Ventilator met grillelement: De ventilator vermindert de felle hitte van de grill en biedt een uitstekende methode om verschillende soorten voedsel, karbonades, steaks, worstjes enz. Te grillen, waardoor het gelijkmatig bruin wordt en de warmte wordt verdeeld, zonder het voedsel uit te drogen. De bovenste twee niveaus die voor gebruik worden aanbevolen, en het onderste deel van de oven kunnen worden gebruikt om gerechten tegelijkertijd warm te houden, een uitstekende mogelijkheid bij het bereiden van een gegrild ontbijt. Halve grill (alleen middengedeelte) is ideaal voor kleine hoeveelheden voedsel.</p> |  <p>Light</p>  |
|  <p>Turbo: the heat comes from 3 directions: above, below and from the back of the oven The fan is active. It allows quick cooking, even on several shelves without mixing the aromas. Ideal for large volumes or foods that require intense cooking.</p>  |  <p>Gas ovens offer instantaneous heat control, reduced cooking times and the ability to bake at much lower temperatures than electric ovens.</p>      |
|  <p>All glass inner door: All glass inner door, a single flat surface which is simple to keep clean.</p>   |  <p>The inner door glass: can be removed with a few quick movements for cleaning.</p>  |
|  <p>verlichting</p>   |  <p>Plate rack warming: function for heating or keeping dishes warm. Place the baking tray on the lowest shelf and stack the dishes to be heated.</p> |
|  <p>The oven cavity has 2 different cooking levels.</p>  |  <p>The oven cavity has 4 different cooking levels.</p>  |
|  <p>The oven cavity has 9 different cooking levels.</p>  |  <p>Telescopic rails: allow you to pull out the dish and check it without having to remove it from the oven entirely.</p>                            |
|  <p>Electronic control: Allows you to maintain temperature inside the oven with the precision 2-3 ° C. This enables to cook meals that are very sensitive to temperature changes, such as cakes, souffles, puddings.</p>   |  <p>Tilting grill: the tilting grill can be easily unhooked to move the heating element and clean the roof of the appliance in one simple step.</p>  |
|  <p>Ultrasnelle branders: Krachtige ultrasnelle branders bieden tot 5kw vermogen.</p>  |  <p>Vapor Clean: a simple cleaning function using steam to loosen deposits in the oven cavity.</p>   |
|  <p>The capacity indicates the amount of usable space in the oven cavity in litres.</p>  |  <p>The capacity indicates the amount of usable space in the oven cavity in litres.</p>  |
|  <p>The capacity indicates the amount of usable space in the oven cavity in litres.</p>  |  <p>Knobs control</p>  |



## Benefit (TT)

---

### **True-convection**

The best cooking performances guaranteed by ventilated circular flow

Multiple fans and heating elements guarantee the perfect aerodynamic heat flow, allowing homogeneous and quicker cooking inside the cavity.

### **Gas hob**

Gas provides permanent control of the heat source and the temperature change is immediate

Equipped with a thermocouple, the gas supply is cut off if the flame is extinguished for greater safety.

### **Vapor Clean**

By inserting water into a recess at the bottom of the cavity, steam is generated, which softens the residue and facilitates its removal

By inserting water into a recess at the bottom of the cavity, steam is generated, which softens the residue and facilitates its removal.

### **Single turbine**

The oven has a fan equipped with a circular heating element allowing cooking with rotating heat

### **Isothermic Cavity**

The best cooking performance at the highest energy efficiency

### **Tangential cooling**

New cooling system with tangential fan and airflow from the door to the splashback

### **Multilevel halogen light**

Internal halogen lighting on different levels guarantees excellent visibility

### **Buttons control**

Easy and intuitive timer setting with a simple buttons

### **Telescopic guides**

Easy extraction and safe insertion of trays into the oven thanks to telescopic guides

### **Adjustable height**

Cooker top flushed with the working area thanks to adjustable feet

### **Removable inner glass**

Internal door glasses are easily removable for complete cleaning

### **Multilevel cooking**

Several cooking levels allow maximum flexibility of use

### **Cold door**

During any function, the external door glass is cold, avoiding any risk of burns

### **AirFry (AIRFRY optional accessory)**

Lighter and tastier food thanks to airfry basket (optional accessory)

### **BBQ (optional accessory)**

Barbeque cooking directly in the oven with the double-sided grill (BBQ optional accessory)

### **Pizza stone (optional accessory)**

Baking with refractory stone for soft and crispy pizza and yeast products (STONE optional accessory)