

TR93GR

| | |
|--|-----------------------|
| Categorie fornuis | 90x60 cm |
| N. of cavities with energy label | 2 |
| Cavity heat source | Elektriciteit |
| Type kookplaat | Gas |
| Type primaire oven | Thermogeventileerd |
| Type secundaire oven | Thermogeventileerd |
| Reinigingssysteem primaire oven | Vapor Clean reiniging |
| EAN-code | 8017709294243 |
| Energie-efficiëntieklasse | A |
| Energie-efficiëntieklasse, tweede oven | B |



Design



| | | | |
|---------------------------|---------------------------|--------------------------|------------------------|
| Design | Victoria | Bedieningsknoppen | Smeg Victoria |
| Design | Victoria | Kleur | Inox |
| Kleur | Leigrijs | bedieningsknoppen | |
| Afwerking | Glanzend | Aantal | 10 |
| Afwerking | Gekleurd plaatstaal | bedieningsknoppen | |
| bedieningspaneel | | Kleur serigrafie | Zilver |
| Logo | assembled 50's | Display | Elektronisch 5 toetsen |
| Positie logo | Upstand+ | Deur | Met kader |
| | Bedieningspaneel | Type glas | Zwart |
| Upstand | Ja | Handgreep | Smeg Victoria |
| Kleur kookplaat | Black enamel | Kleur handgreep | Geborsteld inox |
| Type pottendragers | Gietijzeren pottendragers | Plint | Antraciet |
| Bediening | Bedieningsknoppen | | |

Programma's / Functies

| | |
|--|---|
| Aantal kookfuncties | 5 |
| Traditionele bereidingsfuncties | |



Statisch



Geventileerd



Circulatie (ventilator + circulaire)



ECO



Geventileerde onderwarmte

Overige functies

 Ontdooien op tijd

Reinigingsfuncties

 Vapor Clean reiniging

Programma's / Functies secundaire oven

Aantal kookfuncties 1

Traditionele bereidingsfuncties, 2e oven



Circulatie (ventilator + circulaire)

Programma's / Functies derde oven

Aantal functies derde oven 1

Licht 

Grote vlakgrill 

Technische specificaties kookplaat



Totaal aantal kookzones 6

Linksvoor - Gas - 2URP (dual) - 4.20 kW

Linksachter - Gas - AUX - 1.00 kW

Middenvoor - Gas - AUX - 1.00 kW

Middenachter - Gas - SRD - 1.80 kW

Rechtsvoor - Gas - SRD - 1.80 kW

Rechtsachter - Gas - RP - 2.90 kW

Type gasbranders Standaard

Thermobeveiliging

Ja

Automatische vonkontsteking Ja

Branderdeksels

Mat zwart geëmailleerd

Technische specificaties primaire oven



Aantal lampen 1

Aantal ruiten ovendeur 3

Aantal ventilatoren 1

Aantal thermo-reflecterende ruiten 1

Netto volume 1e oven 61 l

Veiligheidsthermostaat Ja

Bruto volume, oven 1 70 l

Koelsysteem Mantelkoeling

Materiaal ovenruimte Ever Clean emaille

Aantal kookniveaus 4

| | | | |
|------------------------------------|--------------------|---|--------------------|
| Type ovenrekken | Metalen zijsteunen | Afmetingen bruikbare interne ovenruimte (hxbxd) | 316x460x412 mm |
| Type licht | Halogeen | | |
| Vermogen lamp | 40 W | | |
| Opties bereidingstijdprogrammering | Begin en eind | Temperatuurregeling | Elektro-mechanisch |
| Opening deur | Side opening | Onderwarmte - vermogen | 1200 W |
| Uitneembare ovendeur | Ja | Bovenwarmte - vermogen | 1000 W |
| Volledig glazen binnendeur | Ja | Grill - vermogen | 1700 W |
| Uitneembaar glas binnendeur | Ja | Grote vlakgrill - vermogen | 2700 W |
| | | Circulatie - vermogen | 2000 W |
| | | Grill type | Elektrisch |
| | | Kantelbare grill | Ja |

Opties primaire oven

| | | | |
|-------------------------------|----|---------------------|--------|
| Timer | Ja | Minimum temperatuur | 50 °C |
| Geluidssignaal einde kooktijd | Ja | Maximum temperatuur | 260 °C |

Technische specificaties secundaire oven



| | | | |
|----------------------|--------------------|---|--------------------|
| Netto volume 2e oven | 62 l | Volledig glazen binnendeur | Ja |
| Bruto volume, oven 2 | 69 l | Uitneembaar glas binnendeur | Ja |
| Materiaal ovenruimte | Ever Clean emaille | Aantal ruiten ovendeur | 2 |
| Aantal kookniveaus | 9 | Aantal thermo-reflecterende ruiten | 1 |
| Type ovenrekken | Metalen zijsteunen | Veiligheidsthermostaat | Ja |
| Aantal lampen | 1 | Koelsysteem | Mantelkoeling |
| Type lamp | Halogeen | Afmetingen bruikbare interne ovenruimte (hxbxd) | 605x275x370 mm |
| Vermogen lamp | 40 W | Temperatuurregeling | Elektro-mechanisch |
| Opening deur | Side opening | Circulatie - vermogen | 2500 W |
| Uitneembare ovendeur | Ja | | |

Opties secundaire oven

| | | | |
|---------------------|-------|---------------------|--------|
| Minimum temperatuur | 50 °C | Maximum temperatuur | 245 °C |
|---------------------|-------|---------------------|--------|

Technische specificaties derde oven



| | | | |
|-----------------------|------|-----------------------------|----|
| Netto volume, 3e oven | 36 l | Uitneembaar glas binnendeur | Ja |
| Bruto volume, oven 3 | 41 l | | |

| | | | |
|-----------------------------------|--------------------|--|--------------------|
| Materiaal ovenruimte | Ever Clean emaille | Aantal ruiten ovendeur | 3 |
| Aantal kookniveaus | 2 | Aantal thermo-reflecterende ruiten | 1 |
| Type ovenrekken | Metalen zijsteunen | Veiligheidsthermostaat | Ja |
| Aantal lampen | 1 | Koelsysteem | Mantelkoeling |
| Type lamp | Halogeen | Afmetingen bruikbare interne ovenruimte (hxbxd) | 169x440x443 mm |
| Vermogen lamp | 40 W | Temperatuurregeling | Elektro-mechanisch |
| Opening deur | Neerwaarts | Grote vlakgrill - vermogen | 2700 W |
| Uitneembare ovendeur | Ja | Type grill | Elektrisch |
| Volledig glazen binnendeur | Ja | Kantelbare grill | Ja |

Opties derde oven

| | | | |
|----------------------------|-------|----------------------------|--------|
| Minimum temperatuur | 50 °C | Maximum temperatuur | 260 °C |
|----------------------------|-------|----------------------------|--------|

Meegeleverde accessoires primaire oven en kookplaat



| | | | |
|--|---|--|---|
| Gietijzeren wokring | 1 | Bakplaat (40 mm) | 1 |
| Gietijzeren houder t.b.v. caffettiera | 1 | Inzetrooster | 1 |
| Ovenrooster met stop | 2 | Telescopische geleiders, gedeeltelijk uitschuifbaar | 1 |

Meegeleverde accessoires secundaire oven



| | | | |
|-----------------------------|---|-------------------------|---|
| Ovenrooster met stop | 3 | Bordenwarmhouder | 1 |
|-----------------------------|---|-------------------------|---|

Meegeleverde accessoires derde oven

| | | | |
|-----------------------------|---|-------------------------|---|
| Ovenrooster met stop | 1 | Bakplaat (40 mm) | 1 |
|-----------------------------|---|-------------------------|---|

Elektrische aansluiting

| | | | |
|--------------------------------|-----------|-------------------------|-------------------------|
| Nominale aansluitwaarde | 8300 W | Electric cable | Installed, Single phase |
| Stroom | 36 A | Type stroomkabel | Double and Three Phase |
| Spanning | 220-240 V | Frequentie | 50/60 Hz |
| Spanning 2 (V) | 380-415 V | Connection box | 5 polig |

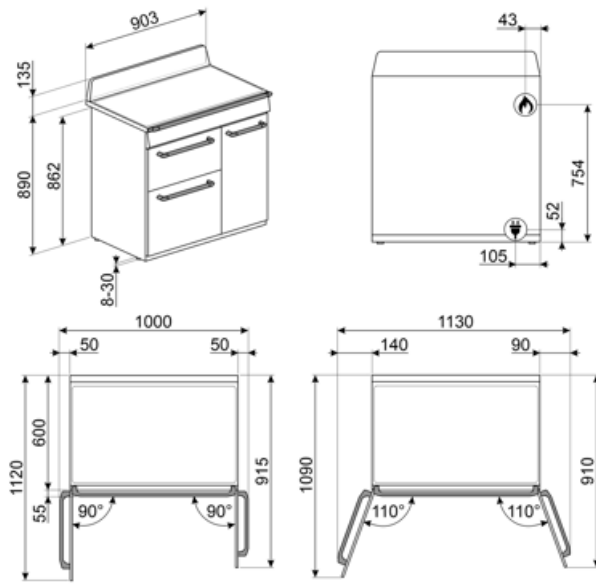

Compatible Accessories

AIRFRY



BGTR9



Cast iron grill plate suitable for 90 cm Victoria, 60 and 90 cm Master and Sinfonia cookers

BN640



Enamelled tray suitable for 45cm and 60cm ovens. Depth 540 mm. Perfect for cooking and roasting meat and fish in sauces. Also ideal for experimenting with lighter and crunchy side dishes

GTP



Partially extractable telescopic guides (1 level), suitable for traditional ovens. Made in stainless steel, they guarantee stability and facilitate the smooth extraction of the trays.

KIT1TR9N



Splashback black, 90cm, suitable for TR90 and TR93 Victoria cookers

PALPZ



Pizzapallet inox met ploibaar handvat, 315x325 mm

SMOLD

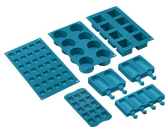

Set van 7 siliconen vormen voor ijsjes, pralines, ijsblokjes of porties. -60°C tot 230°C.

BBQ

Dubbelzijdig



BN620-1



Enamelled tray suitable for 45cm and 60cm ovens. Depth 20 mm. Perfect for a wide range of savoury and sweet baking.

BNP608T



Teflon bakplaat, 8mm diep

GTT



Volledig uitschuifbare telescopische rails (1 niveau) voor traditionele ovens (SF-).

KITH93



Height extension kit (950mm), black, suitable for TR93 cookers (945-960mm)

SFLK1













Child lock















STONE



Rectangular refractory stone Ideal for cooking pizzas with the same results as a typical wood-fired oven. Can also be used for baking bread, focaccias and other recipes such as pies, flans or biscuits Dimensions: L42 x H1,8 x P37,5 cm.

Symbols glossary

| | | | |
|--|--|---|--|
|  | |  | B: Product energy rating, measured from A+++ to D / G depending on the product family. |
|  | Heavy duty cast iron pan stands: for maximum stability and strength. |  | Installation in column: Installation in column |
|  | Air cooling system: to ensure a safe surface temperatures. |  | Defrost by time: Manual defrost function. At the end of the set duration, the function stops. |
|  | Double glazed doors: Number of glazed doors. |  | Triple glazed doors: Number of glazed doors. |
|  | Ever Clean Enamel: Ever Clean enamel is applied electrostatically, corner to corner and edge to edge to prevent cracking or cracks over time. It is a particular pyrolytic enamel, resistant to acids which, in addition to being pleasantly bright, promotes greater cleaning of the oven walls, thanks to its lower porosity. It is baked at over 850 ° C and slowly polymerized at a scientifically determined rate to ensure uniform depth and strength Ever Clean enamel creates an impeccable finish both on the inside of the oven and on the trays, making the surfaces of the oven incredibly easy to maintain over time as it reduces the adhesion of fat during cooking |  | Circogas: In gasovens verdeelt de ventilator de warmte snel en gelijkmatig over de ovenruimte, waardoor smaakoverdracht wordt vermeden bij het tegelijkertijd bereiden van een aantal verschillende gerechten. In elektrische ovens voltooit deze combinatie het koken van voedsel dat aan de oppervlakte klaar is, maar dat van binnen meer moet worden gekookt, zonder verder bruin te worden. |
|  | Ventilator met bovenste en onderste elementen: De elementen in combinatie met de ventilator zijn bedoeld om een meer gelijkmatige warmte te bieden, een methode die vergelijkbaar is met conventioneel koken, dus voorverwarmen is vereist. Het meest geschikt voor items die langzaam koken vereisen. |  | Alleen boven- en onder element: een traditionele kookmethode die het meest geschikt is voor losse items in het midden van de oven. de bovenkant van de oven zal altijd het heetst zijn. Ideaal voor gebraden vlees, fruitcake, brood etc. |
|  | Circulaire: De combinatie van de ventilator en het ronde element eromheen zorgt voor een hete lucht kookmethode. Dit biedt vele voordelen, waaronder geen voorverwarmen als de kooktijd meer dan 20 minuten bedraagt, geen smaakoverdracht bij het gelijktijdig bereiden van verschillende soorten voedsel, minder energie en kortere kooktijden. Geschikt voor alle soorten voedsel. |  | De combinatie van de grill, de ventilator en onderwarmte is interessant voor het bereiden van kleine hoeveelheden. |
|  | Grill element: Using of grill gives excellent results when cooking meat of medium and small portions, especially when combined with a rotisserie (where possible). Also ideal for cooking sausages and bacon. |  | Light |
|  | All glass inner door: All glass inner door, a single flat surface which is simple to keep clean. |  | The inner door glass: can be removed with a few quick movements for cleaning. |

-
-  Side lights: Two opposing side lights increase visibility inside the oven.
 -  Plate rack warming: function for heating or keeping dishes warm. Place the baking tray on the lowest shelf and stack the dishes to be heated.
 -  The oven cavity has 2 different cooking levels.
 -  The oven cavity has 4 different cooking levels.
 -  The oven cavity has 9 different cooking levels.
 -  Telescopic rails: allow you to pull out the dish and check it without having to remove it from the oven entirely.
 -  Electronic control: Allows you to maintain temperature inside the oven with the precision 2-3 ° C. This enables to cook meals that are very sensitive to temperature changes, such as cakes, souffles, puddings.
 -  Tilting grill: the tilting grill can be easily unhooked to move the heating element and clean the roof of the appliance in one simple step.
 -  Ultra rapid burners: Powerful ultra rapid burners offer up to 5kw of power.
 -  Vapor Clean: a simple cleaning function using steam to loosen deposits in the oven cavity.
 -  The capacity indicates the amount of usable space in the oven cavity in litres.
 -  The capacity indicates the amount of usable space in the oven cavity in litres.
 -  The capacity indicates the amount of usable space in the oven cavity in litres.
 -  Knobs control

Benefit (TT)

Gas hob

Gas provides permanent control of the heat source and the temperature change is immediate

Equipped with a thermocouple, the gas supply is cut off if the flame is extinguished for greater safety.

Vapor Clean

By inserting water into a recess at the bottom of the cavity, steam is generated, which softens the residue and facilitates its removal

By inserting water into a recess at the bottom of the cavity, steam is generated, which softens the residue and facilitates its removal.

Buttons control

Easy and intuitive timer setting with a simple buttons

True-convection

The best cooking performances guaranteed by ventilated circular flow

Multiple fans and heating elements guarantee the perfect aerodynamic heat flow, allowing homogeneous and quicker cooking inside the cavity.

Multilevel cooking

Several cooking levels allow maximum flexibility of use

Multilevel halogen light

Internal halogen lighting on different levels guarantees excellent visibility

Removable inner glass

Internal door glasses are easily removable for complete cleaning

Tangential cooling

New cooling system with tangential fan and airflow from the door to the splashback

Telescopic guides

Easy extraction and safe insertion of trays into the oven thanks to telescopic guides

Adjustable height

Cooker top flushed with the working area thanks to adjustable feet

Cold door

During any function, the external door glass is cold, avoiding any risk of burns

AirFry (AIRFRY optional accessory)

Lighter and tastier food thanks to airfry basket (optional accessory)

BBQ (optional accessory)

Barbeque cooking directly in the oven with the double-sided grill (BBQ optional accessory)

Pizza stone (optional accessory)

Baking with refractory stone for soft and crispy pizza and yeast products (STONE optional accessory)

Isothermic Cavity

The best cooking performance at the highest energy efficiency

Single turbine

The oven has a fan equipped with a circular heating element allowing cooking with rotating heat