

# TRU36GMDGC

Range size	36"
N. of cavities with energy label	1
Oven energy source	Electricity
Main oven	Thermo-ventilated
Cleaning system - Main oven	VaporClean
EAN code	8017709280086



## Aesthetic









<b>Aesthetics</b>	Victoria	<b>Control setting type</b>	Control knobs
<b>Series</b>	Divina Cucina	<b>Control knobs</b>	Victoria
<b>Design</b>	Victoria	<b>Controls color</b>	Stainless steel
<b>Color</b>	Decorated / Special	<b>No. of controls</b>	8
<b>Finishing</b>	Glossy	<b>Silkscreen color</b>	Silver
<b>Control panel finish</b>	Stainless steel	<b>Display</b>	Touch
<b>Decoration / Special color</b>	Carretto	<b>Door</b>	With frame
<b>Collaborations</b>	SMEG & Dolce&Gabbana	<b>Door glass type</b>	Stopsol
<b>Logo</b>	Silkscreened	<b>Handle</b>	Victoria
<b>Logo position</b>	Control panel	<b>Handle color</b>	Polished chrome
<b>Upstand</b>	Yes	<b>Storage compartment</b>	Drawer
<b>Cooktop color</b>	Black enamel	<b>Feet</b>	none
<b>Grates</b>	Cast Iron	<b>Plinth</b>	Anthracite

## Programs / Functions

No. of cooking functions	7
--------------------------	---

### Traditional cooking functions

-  Static
-  Fan-assisted
-  True European convection
-  Small grill
-  Large grill
-  Large grill + Fan
-  Bottom





















### Other functions

-  Defrost by time

## Cooktop technical features

-  **Cooking zones** 5
- Front-left - Gas - Rapid - 2800 W - 9500 BTU
- Rear-left - Gas - Semi-rapid - 1800 W - 6000 BTU
- Center - Gas - Dual ultra-rapid - 5300 W - 18000 BTU
- Rear-right - Gas - Semi-rapid - 1800 W - 6000 BTU
- Front-right - Gas - AUX - 1000 W - 3500 BTU
- Burners type** Standard
- Gas safety valves** Yes
- Automatic gas ignition** Yes
- Burner caps** Enameled matte black

## Main Oven Technical Features

-  **No. of lights** 2
-  **Fan number** 3
-  **Net volume of the cavity** 4.20 cu. ft.
-  **Volume** 4.45 cu. ft.
-  **Cavity material** EverClean enamel
-  **No. of shelves** 5
-  **Shelves type** Metal racks
-  **Light type** Halogen
-  **Light Power** 40 W
-  **Time setting** Start and end
-  **Light on when door is open** Yes
-  **Door opening** Drop-down
-  **Removable door** Yes
-  **Full-glass inner door** Yes
-  **Removable inner door** Yes
-  **Total no. of door glasses** 3
-  **No. of thermo-reflective door glasses** 2
-  **Safety thermostat** Yes
-  **Cooling system** Tangential
-  **Inner cavity dimensions (HxWxD)** 340x750x427 "
-  **Temperature control** Electro-mechanical
- Bottom heating element - Power** 1700 W
- Upper heating element - Power** 1200 W
- Grill power** 1700 W
- Large grill - Power** 2900 W
- Circular heating element - Power** 1550 W
- Grill type** Electric
- Soft Close system** Yes

## Main oven options

Timer	Yes	Minimum Temperature	122 °F
End-of-cooking alarm	Yes	Maximum temperature	500 °F

## Accessories included for main oven and cooktop



Cast iron wok support	1	1.6"-deep tray	1
Moka cast-iron stand	Moka ring	Telescopic Guide rails, total Extraction	1
TOP Oven grid with back stop	2		

## Electrical Connection

Plug	(B) USA 120V	Voltage (V)	120/208 V
Electrical connection rating	3300 W	Power cord length	47 1/4 "
Current	15 A	Frequency	60 Hz
Voltage	120-240 V	Terminal block	5 poles

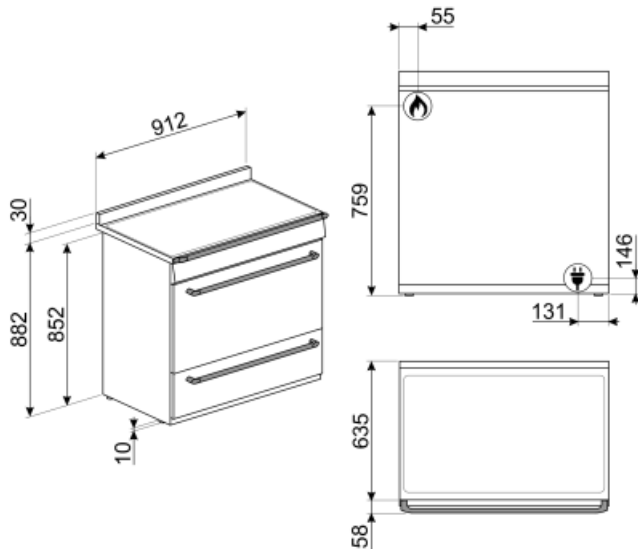

---

## Not included accessories

---



### PRTX

Refractory pizza stone with handles. D=35cm Not suitable for microwave ovens. Suitable for gas ovens, to be put on the griddle.



### BGTR9

Cast iron grill plate suitable for 90 cm Victoria, 60 and 90 cm Master and Sinfonia cookers



### KIT1TR9N

Splashback, 90x75 cm suitable for TR9 Victoria cookers, black



### KITHTR90

Height extension kit (950 mm), suitable for Victoria TR90 cookers

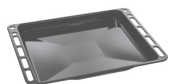

### BN640

Enamelled tray, 40mm deep



### BNP608T

Teflon-coated tray, 8mm depth, to be placed on the grid



### PPR9

Refractory pizza stone without handles. Squared stone (HxWxD): 0.9" x 25.2" x 14.75". Also suitable for gas ovens, to be placed on a rack



### BN620-1

















Enamelled tray, 20mm deep













### PALPZ

Pizza shovel with fold away handle width: 315mm length : 325mm

## Symbols glossary (TT)

 <p>Triple Fan Technology: The oven is equipped with an exclusive three fan system, which, combined with the increased power of the motors, enables excellent cooking performance. The two large side fans distribute the air around the outer perimeter of the cavity while the smaller central fan increases ventilation by creating a vertical vortex of heat. Accordingly, the temperature within the cavity is uniform, allowing food to be cooked evenly on all five levels, like in professional kitchens.</p>	 <p>Heavy duty cast iron pan stands: for maximum stability and strength.</p>
 <p>Installation in column: Installation in column</p>	 <p>Air cooling system: to ensure a safe surface temperatures.</p>
 <p>Defrost by time: with this function the time of thawing of foods are determined automatically.</p>	 <p>Triple glazed doors: Number of glazed doors.</p>
 <p>Enamel interior: The enamel interior of all Smeg ovens have a special antacid lining which helps keep the interior clean by reducing the amount of cooking grease adhering to it.</p>	 <p>Fan with upper and lower elements: The elements combined with the fan aim to provide more uniform heat, a similar method to conventional cooking, so pre-heat is required. Most suitable for items requiring slow cooking methods.</p>
 <p>Upper and lower element only: a traditional cooking method best suited for single items located in the centre of the oven. the top pf the oven will always be hottest. Ideal for roast, fruit cakes, bread etc.</p>	 <p>Lower heating element only: This function is ideal for foods that require extra base temperature without browning, e.g. pastry dishes, pizza. Also suitable for slow cooking of stews and casseroles.</p>
 <p>True European Convection: The combination of the fan and circular heating element around it provides many benefits, including no preheat if cooking time is longer than 20 minutes, no flavor transfer when cooking different foods at the same time, lower energy consumption, and shorter cooking times. Suitable for all types of food preparations.</p>	 <p>Grill element: Using of grill gives excellent results when cooking meat of medium and small portions, especially when combined with a rotisserie (where possible). Also ideal for cooking sausages and bacon.</p>
 <p>Half grill: For rapid cooking and browning of foods. Best results can be obtained by using the top shelf for small items, the lower shelves for larger ones, such as chops or sausages. For half grill heat is generated only at the centre of the element, so is ideal for smaller quantities.</p>	 <p>Fan with grill element: The fan reduces the fierce heat from the grill, providing an excellent method of grilling various foods, chops, steaks, sausages etc. giving even browning and heat distribution, without drying out the food. The top two levels recommended for use, and the lower part of the oven can be used to keep items warm at the same time, an excellent facility when cooking a grilled breakfast. Half grill (centre portion only) is ideal for small quantities of food.</p>
 <p>All glass inner door: All glass inner door, a single flat surface which is simple to keep clean.</p>	 <p>The inner door glass: can be removed with a few quick movements for cleaning.</p>

- 
- |  |   |
|--|---|
|  Side lights: Two opposing side lights increase visibility inside the oven.  |  Automatic opening: some models have Automatic opening door when the cycle is finished which is a perfect solution for handle-less kitchen units as no handle is needed. For safety reasons, the door locks automatically when the machine is in use to avoid it being opened inadvertently. |
|  The oven cavity has 5 different cooking levels.   |  Soft close: all models are equipped with advanced function of smooth closing of the door, which allows the device to close smoothly and quietly.  |
|  Telescopic rails: allow you to pull out the dish and check it without having to remove it from the oven entirely. |  Ultra rapid burners: Powerful ultra rapid burners offer up to 5kw of power.   |
|  Vapor Clean: a simple cleaning function using steam to loosen deposits in the oven cavity.                        |  The capacity indicates the amount of usable space in the oven cavity in litres.   |
|  ...   |  Knobs control   |

## Benefit (TT)

---

### **True-convection**

The best cooking performances guaranteed by ventilated circular flow.

Multiple fans and heating elements guarantee the perfect aerodynamic heat flow, allowing homogeneous and quicker cooking inside the cavity.

### **Gas hob**

Induction offers fast cooking and precise temperature control

Equipped with a thermocouple, the gas supply is cut off if the flame is extinguished for greater safety

### **Vapor Clean**

By inserting water into a recess at the bottom of the cavity, steam is generated, which softens the residue and facilitates its removal

By inserting water into a recess at the bottom of the cavity, steam is generated, which softens the residue and facilitates its removal.

### **Touch control**

Easy and intuitive timer setting with a single touch

### **Isothermic Cavity**

The best cooking performance at the highest energy efficiency

### **Triple Turbine**

The oven has three fans and two circular heating elements, allowing cooking with rotating heat

### **Tangential cooling**

New cooling system with tangential fan and airflow from the door to the splashback

### **Soft close**

The door is equipped with a specific system for silent closing

### **Multilevel halogen light**

Internal halogen lighting on different levels guarantees excellent visibility

### **Telescopic guides**

Easy extraction and safe insertion of trays into the oven thanks to telescopic guides

### **Adjustable height**

Cooker top flushed with the working area thanks to adjustable feet

### **Removable inner glass**

Internal door glasses are easily removable for complete cleaning

### **Multilevel cooking**

Several cooking levels allow maximum flexibility of use

### **Cold door**

During any function, the external door glass is cold, avoiding any risk of burns

### **AirFry (AIRFRY optional accessory)**

Lighter and tastier food thanks to airfry basket

### **Drawer storage compartment**

More space thanks to the lower compartment, ideal for storing accessories or cooking utensils

### **BBQ (optional accessory)**

Barbeque cooking directly in the oven with the double-sided grill

### **Pizza stone (optional accessory)**

Baking with refractory stone for soft and crispy pizza and yeast products (STONE optional accessory)