

U8F082DE



Product Family	Freezers
Installation	Built-in
Built-In Niche	82-87
Category	Under counter
Reference width	Until 60
Reference height	Until 100
Cooling type	Static
Hinge type	Door on door
Hinge position	Right
Reversible door	Yes



Aesthetics

Aesthetic	Universal	Side material	Metal
Colour	White	Logotipo	Logotipo serigrafado
Design	Flat	Cor do perfil das gavetas	Silver
Material	Steel		

Freezer compartment features

Internal light in freezer	No
Number of drawers	3

Other technical features

Freezer compartment accessories	Ice cube tray	Refrigerant gas type	R600a
Fast freezing button	Yes	Type of compressor	Standard
Power on lamp	Yes	Quantidade de refrigeracao (gr.)	45 g
Temperature alarm lamp	Yes	Espuma expansiva de isolamento	Ciclopentano
Type of temperature control	Electro-mechanical	Peso máximo do painel para a porta do congelador	40 kg
No. of compressors	1		

Etiqueta de Desempenho / Energia - Reg. 2019



Consumo de energia anual	176 kWh/a	Autonomia de conservação sem energia elétrica	13.50 h
Volume líquido total	95 l	4 estrelas - Capacidade de congelamento	7.1 Kg/24h
Classe de eficiência energética	E	Classe climática	SN, N, ST, T
Classe de emissão de ruído acústico aerotransportado	C	EEl	100 %
Soma dos volumes do(s) compartimento(s) congelado(s)	95 l		

Electrical Connection

Plug	(F;E) Schuko	Voltage	230-240 V
Electrical connection rating	120 W	Frequency (Hz)	50 Hz
Current	0,8 A	Comprimento do cabo de alimentação	240 cm

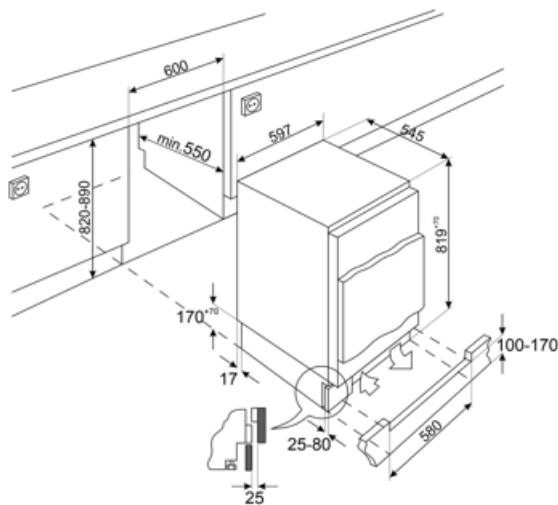

Symbols glossary



Classe de eficiência energética E.



Nicho incorporado