

# U8F082DF1



Product familie	Vriezers
Installatie	Inbouw
Inbouw nismaat	82-87 cm
Categorie	Tafelmodel
Type koelen	Statisch
Type scharnier	Deur-op-deur
Positie scharnier	Rechts
Deur omkeerbaar	Ja



## Design

Design	Universeel	Materiaal zijwanden	Plaatstaal
Kleur	Wit	Kleur zijkanten	Wit
Design	Plat	Logo	Geëst
Materiaal deur	Plaatstaal	Kleur profielen laden	Zilver

## Uitrusting vriezer

Aantal lades	3
--------------	---

## Overige technische eigenschappen

Accessoires vriezer	Ijsblokeshouder	Type koelgas	R600a
Snel-vriestoets	Ja	Type compressor	Standaard
Functioneringindicator (lampje)	Ja	Hoeveelheid koelmiddel	45 g
Indicator (lampje) temperatuuralarm	Ja	Schuimmiddel	Cyclopentaan
Type temperatuurcontrole	Elektro-mechanisch	Max weight door panel (freezer)	41 kg
Aantal compressoren	1		

## Prestaties/Energie label - Reg. 2019



Annual energy consumption	220 kWh/jaar	Conserveringsduur zonder stroom	13,50 h
---------------------------	--------------	---------------------------------	---------

---

Totaal netto volume	95 l	4 star - Freezing capacity	7,1 kg/24h
Energie-efficiëntieklasse	F	Klimaatklasse EEI	SN, N, ST, T 125 %
Emissieklasse voor akoestisch luchtgeluid	C		
Netto inhoud vriesgedeelte	95 l		

## Elektrische aansluiting

---



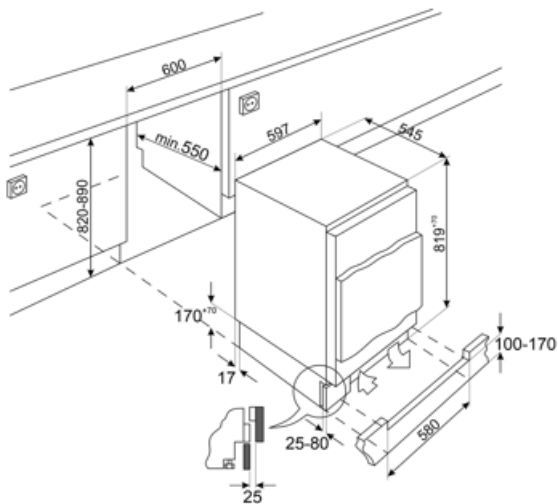

Nominale aansluitwaarde	120 W	Frequentie	50 Hz
Stroom	0,8 A	Lengte voedingskabel	240 cm
Spanning	230-240 V	Stekker	(F;E) Schuko



---

## Symbols glossary

---

	4 stars freezing compartment for better food preservation.		A+: Energy efficiency class A+ helps to save up to 10% energy compared to class A. Maximum performance with minimum consumption is guaranteed.
	Built-in niche		Energie-efficiëntieklasse