

# UKC4172F



Product Family	Refrigerator
Installation	Built-in
Category	Bottom Mount
Built-in niche	178
Reference width	Until 60
Reference height	160 - 200
Cooling type	Static
Defrost	Automatic
Hinge type	Sliding
Hinge position	Right
Reversible door	Yes
EAN code	8017709295325



## Aesthetics



Aesthetics	Universal	Logo	Silk screen
Colour	White	Door shelves profile colour	White
Design	Flat	Drawers profile colour	White
Material	Metal sheet	Colour of glass shelf profile	White
Side material	Steel	Display	LED
Side colour	White	Display position	Interior

## Refrigerator compartment features



No. of adjustable shelves	2	Crisper Cover	Yes
Number of fruit and vegetables drawers	2	Type of crisper/vegetable drawers cover	Glass
Type of adjustable shelves	Glass	Internal light in fridge	Yes
Type of crisper/vegetable drawers cover	Standard	Type of internal light (fridge)	LED

## Refrigerator Inner Door

No. of door shelves with transparent cover	1	No. of bottle shelves	1
--	---	-----------------------	---

---

Number of adjustable door shelves 1

## Other Refrigerator features

---

Accessories Egg tray

## Freezer compartment features

---

Number of drawers 4

## Other Freezer features

---

Accessories 1 ice box

## Other technical features

---

Type of temperature control	Electronic
No. of compressors	1
Refrigerant gas type	R600a
Type of compressor	Standard
Refrigerant Quantity (gr)	76 g
Foam agent	Cyclopentane

## Performance / Energy Label

---

			
Annual energy consumption	289 kWh/year	Noise level	36 dB(A) re 1 pW
Energy efficiency class	F	Thaw time	14.30 h
Airborne acoustical noise emission class	C	4 star - Freezing capacity	5.2 Kg/24h
Total volume	267 l	Climatic class	SN, N, ST
Sum of the volumes of the frozen compartment(s)	106 l	EI	125 %
Sum of the volumes of the chill compartment(s) and the unfrozen compartment(s)	161 l		

## Electrical Connection

---

Plug	(G) UK e Singapore	Voltage (V)	230-240 V
Nominal power	150 W	Frequency (Hz)	50 Hz
Current	1,1 A	Power supply cable length	240 cm

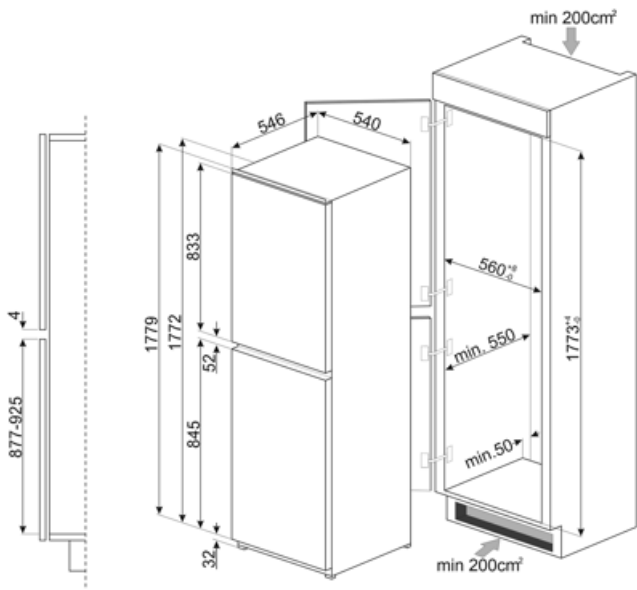

---

## Symbols glossary

---



4 stars freezing compartment for better food preservation.



The automatic defrost system works by automatically defrosting at regular intervals eliminating the need to defrost altogether.



A+: Energy efficiency class A+ helps to save up to 10% energy compared to class A. Maximum performance with minimum consumption is guaranteed.



Energy efficiency class F



LED display: to show programmes, functions and options selected and the time to the end of the cycle.



LED interior lighting: is a more energy efficient and long lasting way of illuminating the interior of the appliance.



Built-in niche