

# UKFF08EW

Product Family	Freezers
Installation	Free Standing
Category	Under counter
Reference width	Until 60 cm
Reference height	Until 100 cm
Cooling type	Static
Hinge type	Standard
Hinge position	Right
Reversible door	Yes



## Aesthetics

Aesthetics	Universal	Handle type	Fixed
Colour	White	Side material	Metal
Design	Flat	Side colour	White
Material	Steel	Logo	Applied
Handle	External	Drawers profile colour	White

## Freezer compartment features

Number of drawers	3
-------------------	---

## Other Freezer features

Ice tray shelf	Yes
----------------	-----

## Other technical features

Freezer compartment accessories	Ice cube tray	Type of compressor	Standard
Type of temperature control	Electro-mechanical	Refrigerant Quantity (gr)	42 g
No. of compressors	1	Foam agent	Cyclopentane
Refrigerant gas type	R600a		

## Performance / Energy Label



---

<b>Annual energy consumption</b>	200 kWh/year	<b>Thaw time</b>	11 h
<b>Total volume</b>	63 l	<b>4 star - Freezing capacity</b>	3,3 kg/24h
<b>Energy efficiency class</b>	E	<b>Climatic class</b>	SN, N, ST, T
<b>Airborne acoustical noise emission class</b>	C	<b>EEl</b>	100 %
<b>Sum of the volumes of the frozen compartment(s)</b>	64 l		

## Electrical Connection

---

<b>Nominal power</b>	119 W	<b>Frequency (Hz)</b>	50 Hz
<b>Current</b>	0,76 A	<b>Plug</b>	(F;E) Schuko
<b>Voltage</b>	220-240 V		

## Logistic Information

---

<b>Width (mm)</b>	480 mm	<b>Height with feet</b>	821 mm
<b>Depth without handle</b>	510 mm	<b>Product width with maximum doors opening</b>	580 mm

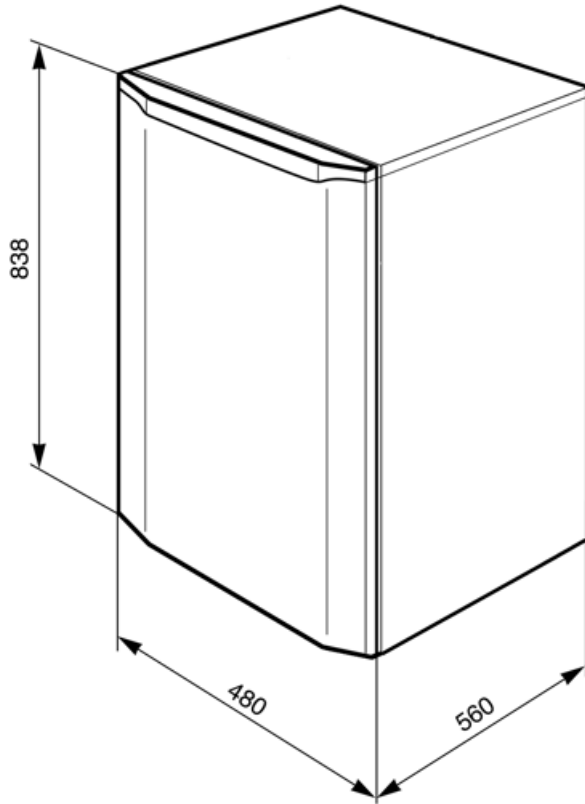

---

## Symbols glossary

---



4 stars freezing compartment for better food preservation.



Energy efficiency class E