

# UKS4C092D



<b>Product Family</b>	Refrigerator
<b>Installation</b>	Built-in
<b>Category</b>	One Door
<b>Built-in niche</b>	88
<b>Reference width</b>	Until 60 cm
<b>Reference height</b>	Until 100 cm
<b>Cooling type</b>	Static
<b>Defrost</b>	Automatic
<b>Hinge type</b>	Sliding
<b>Kitchen panel</b>	Not supplied
<b>Hinge position</b>	Right
<b>Reversible door</b>	Yes
<b>EAN code</b>	8017709346379



## Aesthetics



<b>Aesthetic</b>	Universale	<b>Side colour</b>	White
<b>Colour</b>	White	<b>Logo</b>	Silk screen
<b>Design</b>	Flat	<b>Door shelves profile color</b>	White
<b>Material</b>	Metal sheet	<b>Color of glass shelf profile</b>	White
<b>Handle type</b>	Fixed	<b>Display</b>	LCD
<b>Logo colour</b>	Black	<b>Display position</b>	Interno (cella frigo)
<b>Side material</b>	Steel		

## Refrigerator compartment features



<b>Number of compartments</b>	1	<b>Crisper Cover</b>	Yes
<b>Compartment types</b>	Fruit and vegetable compartment	<b>Type of crisper/vegetable drawers cover</b>	Glass
<b>No. of adjustable shelves</b>	2	<b>No. of lights refrigerator compartment</b>	1
<b>Number of fruit and vegetables drawers</b>	1	<b>Internal light in fridge</b>	Yes
<b>Shelves material</b>	Glass	<b>Type of internal light (fridge)</b>	LED
<b>Type of crisper/vegetable drawers cover</b>	Standard		

## Refrigerator Inner Door

No. of door shelves with transparent cover	1	No. of bottle shelves	1
Number of adjustable door shelves	2		

## Other Refrigerator features

Accessories	Egg tray
-------------	----------

## Freezer compartment features

Internal freezer compartment	Yes
------------------------------	-----

## Other technical features

Type of temperature control	Electronic
No. of compressors	1
Refrigerant gas type	R600a
Type of compressor	Standard
Refrigerant Quantity (g)	28 g
Foam agent	Cyclopentane

## Performance / Energy Label - Reg. 2019

 Annual energy consumption	114 kWh/a	Airborne acoustical noise emissions	36 dB(A) re 1 pW
Energy efficiency class	D	Temperature Rise Time	9,5 h
Airborne acoustical noise emission class	C	4 star - Freezing capacity	2,6 kg/24h
Total net volume	124 l	Climate class	SN, N, ST
Sum of the volumes of the frozen compartment(s)	14 l	EEL	80 %
Sum of the volumes of the chill compartment(s) and the unfrozen compartment(s)	110 l		

## Electrical Connection

Electrical connection rating	100 W	Frequency (Hz)	50 Hz
Current	0,6 A	Power supply cable length	240 cm
Voltage (V)	230-240 V	Plug	(G) UK e Singapore

## Logistic Information

**Width** 548 mm  
**Width of the built-in niche** 560 mm  
**Depth without handle** 549 mm  
**Depth of the built-in niche** 550 mm



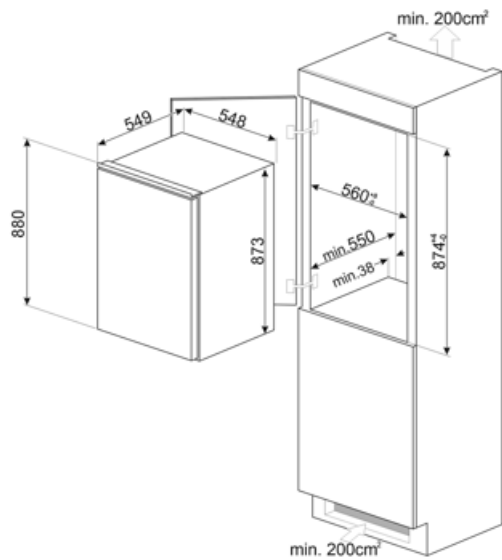

**Height** 873 mm  
**Height of the built-in niche** 880 mm  
**Product width with maximum doors opening** 548 mm  
**Spacer depth** 38 mm



---

## Symbols glossary

---

- |  |   |   |   |
|--|---|---|---|
|  | The automatic defrost system works by automatically defrosting at regular intervals eliminating the need to defrost altogether. |  | Energy efficiency class D   |
|  | LCD display: to optimize performance and simplify the use of the appliance.   |  | LED interior lighting: is a more energy efficient and long lasting way of illuminating the interior of the appliance. |
|  | Built-in niche  |   |   |