

# UKS8F174NF



Product Family	Freezers
Installation	Built-in
Built-In Niche	178
Category	Single door
Cooling type	No Frost
Hinge type	Sliding
Hinge position	Right
Reversible door	Yes



## Aesthetics



Aesthetics	Universal	Side colour	White
Colour	White	Logo	Silk screen
Material	Steel	Drawers profile colour	Silver
Side material	Metal	Display	LCD Touch

## Freezer compartment features

Number of drawers	5
No. of compartments with flap	2

## Other technical features

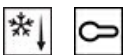

Freezer compartment accessories	Accumulator, Ice cube tray	No. of compressors	1
Functions display	Fast Freezing, Control lock, Temperature Alarm, Cooling timer	Refrigerant gas type	R600a
Fast freezing button	Yes	Type of compressor	Standard
Door open alarm	Acoustic	Refrigerant Quantity (gr)	48 g
Temperature alarm	Acoustic and visual	Foam agent	Cyclopentane
Type of temperature control	Electronic	Metal panel on the back of the fridge	PP+Al foil

## Performance / Energy Label NEW









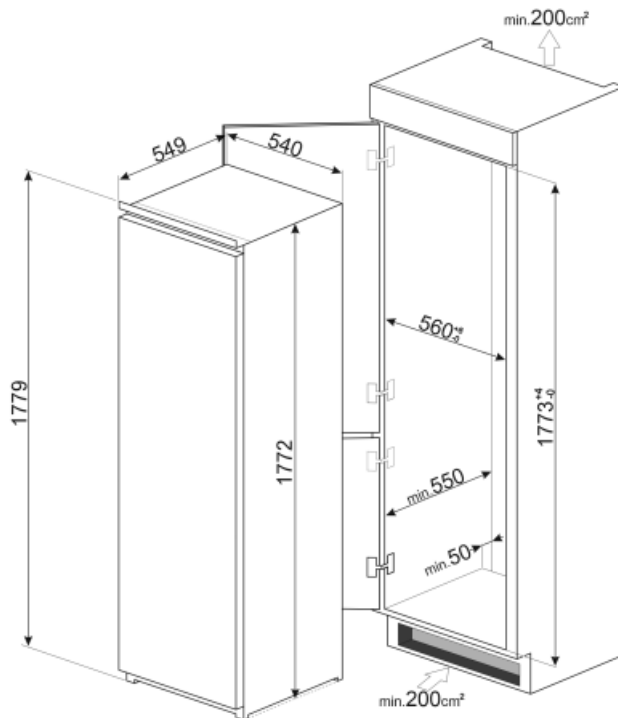

<b>Annual energy consumption</b>	292 KWh/year	<b>Thaw time</b>	7.90 h
<b>Total volume</b>	204 l	<b>4 star - Freezing capacity</b>	15.7 Kg/24h
<b>Energy efficiency class</b>	F	<b>Climatic class</b>	SN, N, ST, T
<b>Airborne acoustical noise emission class</b>	C	<b>EEl</b>	125 %
<b>Sum of the volumes of the frozen compartment(s)</b>	204 l		

## Electrical Connection

<b>Plug</b>	(G) UK e Singapore	<b>Voltage</b>	230-240 V
<b>Nominal power</b>	140 W	<b>Frequency (Hz)</b>	50 Hz
<b>Current</b>	1 A	<b>Power supply cable length</b>	240 cm



## Symbols glossary

	4 stars freezing compartment for better food preservation.		Child lock: some models are fitted with a device to lock the programme/cycle so it cannot be accidentally changed.
	A+: Energy efficiency class A+ helps to save up to 10% energy compared to class A. Maximum performance with minimum consumption is guaranteed.		Energy efficiency class F
	LCD display: to optimize performance and simplify the use of the appliance.		Fast freezing: The fast freezing function brings the temperature of the compartment down when activated a few hours prior to usage.
	Built-in niche		No Frost: The No Frost and Frost free systems prevent ice from forming so that no defrosting is required.