

UKU8F082DF1



| | |
|-----------------|---------------|
| Product Family | Freezers |
| Installation | Built-in |
| Built-In Niche | 82-87 |
| Category | Under counter |
| Cooling type | Static |
| Hinge type | Door on door |
| Hinge position | Right |
| Reversible door | Yes |



Aesthetics

| | | | |
|------------|-----------|------------------------|-------------|
| Aesthetics | Universal | Side material | Metal |
| Colour | White | Side colour | White |
| Design | Flat | Logo | Silk screen |
| Material | Steel | Drawers profile colour | Silver |

Freezer compartment features

| | |
|-------------------|---|
| Number of drawers | 3 |
|-------------------|---|

Other technical features

| | | | |
|---------------------------------|--------------------|---------------------------------------|--------------|
| Freezer compartment accessories | Ice cube tray | Refrigerant gas type | R600a |
| Fast freezing button | Yes | Type of compressor | Standard |
| Power on lamp | Yes | Refrigerant Quantity (gr) | 45 g |
| Temperature alarm lamp | Yes | Foam agent | Cyclopentane |
| Type of temperature control | Electro-mechanical | Max weight door panel (freezer) | 41 kg |
| No. of compressors | 1 | Metal panel on the back of the fridge | PP+Al foil |

Performance / Energy Label NEW



| | | | |
|---------------------------|--------------|-----------|---------|
| Annual energy consumption | 220 KWh/year | Thaw time | 13.50 h |
|---------------------------|--------------|-----------|---------|

| | | | |
|--|------|-----------------------------------|--------------|
| Total volume | 95 l | 4 star - Freezing capacity | 7.1 Kg/24h |
| Energy efficiency class | F | Climatic class | SN, N, ST, T |
| Airborne acoustical noise emission class | C | EEl | 125 % |
| Sum of the volumes of the frozen compartment(s) | 95 l | | |

Electrical Connection

| | | | |
|----------------------|--------------------|----------------------------------|-----------|
| Plug | (G) UK e Singapore | Voltage | 230-240 V |
| Nominal power | 120 W | Frequency (Hz) | 50 Hz |
| Current | 0.8 A | Power supply cable length | 240 cm |

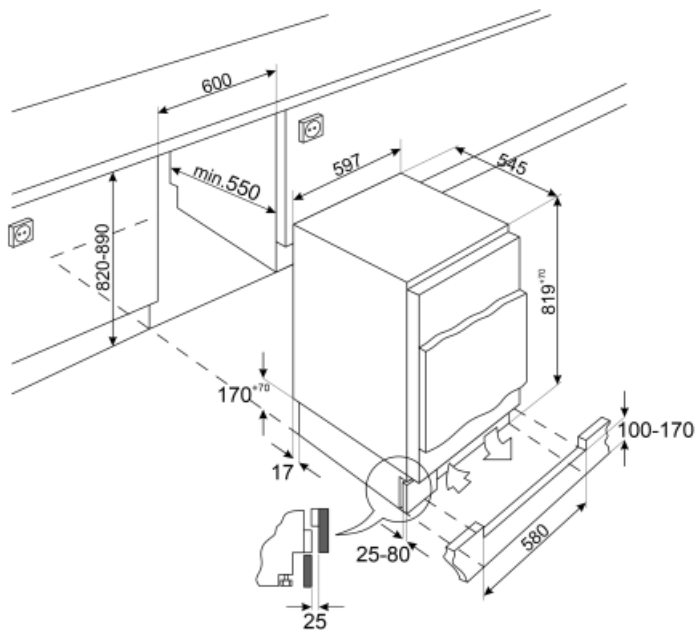

Symbols glossary



4 stars freezing compartment for better food preservation.



Energy efficiency class F



A+: Energy efficiency class A+ helps to save up to 10% energy compared to class A. Maximum performance with minimum consumption is guaranteed.



Built-in niche