

UKU8F082DF1



Product Family	Freezers
Installation	Built-in
Built-In Niche	82-87 cm
Category	Under counter
Cooling type	Static
Hinge type	Door on door
Hinge position	Right
Reversible door	Yes



Aesthetics

Aesthetic	Universale	Side material	Metal
Colour	White	Side colour	White
Design	Flat	Logo	Silk screen
Material	Steel	Drawers profile color	Silver

Freezer compartment features

Number of drawers	3
-------------------	---

Other technical features

Freezer compartment accessories	Ice cube tray	Refrigerant gas type	R600a
Fast freezing button	Yes	Type of compressor	Standard
Power on lamp	Yes	Refrigerant Quantity (g)	45 g
Temperature alarm lamp	Yes	Foam agent	Cyclopentane
Type of temperature control	Electro-mechanical	Max weight door panel (freezer)	41 kg
No. of compressors	1	Metal panel on the back of the fridge	PP+Al foil

Performance / Energy Label - Reg. 2019



Annual energy consumption	220 kWh/a	Temperature Rise Time	13,50 h
---------------------------	-----------	-----------------------	---------



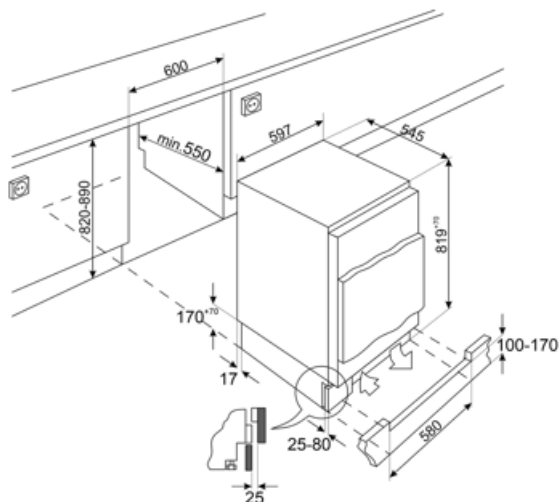

Total net volume	95 l	4 star - Freezing capacity	7,1 kg/24h
Energy efficiency class	F	Climate class	SN, N, ST, T
Airborne acoustical noise emission class	C	EI	125 %
Sum of the volumes of the frozen compartment(s)	95 l		

Electrical Connection

Electrical connection rating	120 W	Frequency (Hz)	50 Hz
Current	0,8 A	Power supply cable length	240 cm
Voltage	230-240 V	Plug	(G) UK e Singapore



Symbols glossary

- | | | | |
|--|--|---|--|
|  | 4 stars freezing compartment for better food preservation. |  | A+: Energy efficiency class A+ helps to save up to 10% energy compared to class A. Maximum performance with minimum consumption is guaranteed. |
|  | Built-in niche |  | Energy efficiency class F |