

C9174DN2D



Product Family	Refrigerator
Installation	Built-in
Category	Bottom Mount
Built-in niche	178
Reference width	Until 60
Reference height	160 - 200
No-Frost system	Total
Cooling type	Total No Frost - Double Cooling system
Defrost	Automatic
Hinge type	Door on door
Hinge position	Right
Reversible door	Yes
EAN code	8017709337230



Aesthetics



Aesthetics	Universal	Door shelves profile colour	Silver
Colour	White	Drawers profile colour	Silver
Material	Metal sheet	Colour of glass shelf profile	Chrome
Side material	Steel	Display	LCD
Side colour	White	Display position	Interior (on the top)
Logo	Silk screen		

Refrigerator compartment features



No. of adjustable shelves	3	Type of crisper/vegetable drawers cover	Glass
Number of fruit and vegetables drawers	1	No. of lights	3
Type of adjustable shelves	Glass	Life Plus zone-0°C	Yes
Type of crisper/vegetable drawers cover	Standard	Internal light in fridge	Yes
Crisper Cover	Yes	Type of internal light (fridge)	LED

Refrigerator Inner Door

No. of door shelves with transparent cover	1	No. of bottle shelves	1
---	---	------------------------------	---

Number of adjustable door shelves 2

Other Refrigerator features



Accessories
MultiFlow

Egg tray
Metal

Fan

Yes

Freezer compartment features

Number of drawers 3

Other Freezer features

Accessories 1 ice box

Other technical features



Functions display	Fast freezing, Fast cooling, ECO, Temperature alarm
Temperature alarm lamp	Yes
Door open alarm	Yes
Temperature Alarm	Yes
Type of temperature control	Electronic
No. of compressors	1
Refrigerant gas type	R600a
Type of compressor	Variable Speed Compressor
Refrigerant Quantity (gr)	58 g
Max weight door panel (fridge)	21 kg
Foam agent	Cyclopentane
Max weight door panel (freezer)	21 kg

Performance / Energy Label

 Annual energy consumption	173 KWh/year	Noise level	35 dB(A) re 1 pW
Energy efficiency class	D	Thaw time	11.00 h
Airborne acoustical noise emission class	B	4 star - Freezing capacity	7.3 Kg/24h
Total volume	244 l	Climatic class	SN, N, ST, T
Sum of the volumes of the frozen compartment(s)	62 l	EEl	80 %







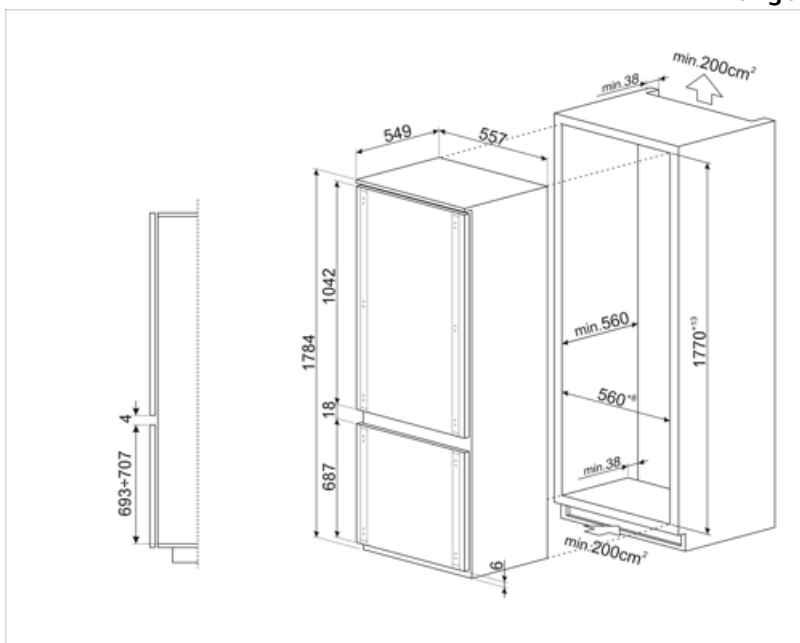



Sum of the volumes of the chill compartment(s) and the unfrozen compartment(s) 182 l

Electrical Connection

Plug	(F;E) Schuko	Voltage (V)	230-240 V
Nominal power	140 W	Frequency (Hz)	50 Hz
Current	1,1 A	Power supply cable length	240 cm



Symbols glossary

-  The automatic defrost system works by automatically defrosting at regular intervals eliminating the need to defrost altogether.
-  Economical mode: Analyzes fridge functioning during the activation and optimizes the operating cycle in order to reduce power consumption.
-  Fast freezing: The fast freezing function brings the temperature of the compartment down when activated a few hours prior to usage.
-  Life Plus 0°C: The temperature in the Lifeplus compartments is kept at 0°C, which preserves fresh meat and fish longer.
-  Built-in niche
-  Multiflow Cooling System: the Multiflow ventilation system allows an even distribution of cool air around the fridge cabinet. The stainless steel panel gives a more premium look to the appliance.
-  LCD display: to optimize performance and simplify the use of the appliance.
-  Ventilated: Forced distribution of cold air in the refrigerator compartment, which allows even temperature distribution within the fridge.
-  LED interior lighting: is a more energy efficient and long lasting way of illuminating the interior of the appliance.
-  Inverter technology: The evolution of Smeg's driers towards more intelligent and environmentally sustainable models has led to the choice of using Inverter technology with heat pumps, which reduces significantly energy consumption.
-  Energy efficiency class D